



Plastics

PRODUCT INSPECTION

# Plastic production and processing

Overview of the product portfolio

# The World of Plastics: Production and Processing

The requirements for plastic manufacturers and processors around the globe are becoming increasingly complex. Efficiency, precision, and sustainability combined with profitability are at the center of every production chain. Whether in handling raw materials, planning a stable and error-free production process, or considering profitability in light of global raw material markets and material fluctuations: companies must continually adapt to remain competitive. The challenges and opportunities of the circular economy demand innovative solutions to make optimal use of valuable resources while ensuring the highest quality standards.

As a partner to the plastics industry, Sesotec offers ideal support for these tasks with its comprehensive product portfolio. The intelligent metal detection and separation solutions ensure reliable identification and removal of contaminants, resulting in consistently high product quality—regardless of fluctuations in material flows. Tailored solutions not only make production more predictable, but also reduce waste and efficiently return valuable raw materials to the production cycle. This enables maximum profitability and sustainability in the plastics industry.

In the best hands:  
With experience and know-how for every application.



Read on to discover  
everything you need to  
know to optimize your  
production processes:

- Detect | Separate | Protect: How to set up your production line securely and efficiently with the best high-tech hardware.
- Maximum profitability through the ideal combination of hardware, smart data management, and service.
- The right product for every application: Benefit from our 50 years of expertise.



# Your Priorities. Our Answers.

When developing our solutions for the plastics industry, we focused on one key aspect: your priorities. Through in-depth analysis and intensive discussions, we identified the most critical requirements for foreign object detection in plastic production processes. Based on this, we researched innovative solutions intensively. The result is our Sesotec Priority Concept, which provides you with practical and future-proof answers to the challenges of plastic production—from increasing efficiency to ensuring consistent product quality in a dynamic market environment.

## P1 Material Efficiency

Rejects mean material waste. This can occur when a system is defective, often caused by contamination in the raw material. A defective system costs time and money – both through production stoppage and repair work. Unplanned downtime is minimized by using optimal detection technologies for raw materials and fast service availability.

## P2 Process Safety

Producing consistently high-quality products is the foundation of economic success, maximizing yields while minimizing complaints. Production processes must be optimized and rejects reduced so that companies can increase their competitiveness and operate more sustainably.

## P3 Quality Assurance

Constantly high product quality is essential for economic success. By optimizing production processes and reducing waste, companies can improve their competitiveness and ensure more sustainable business practices.

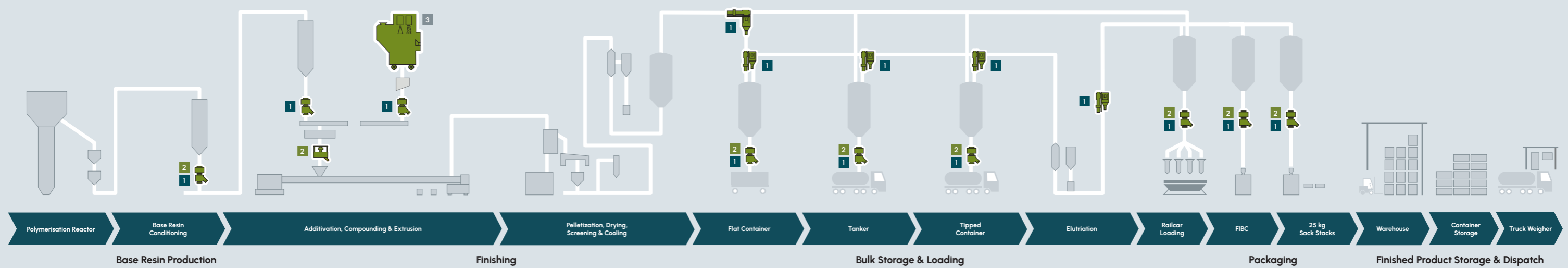

### 1 Metal Detectors & Metal Separators

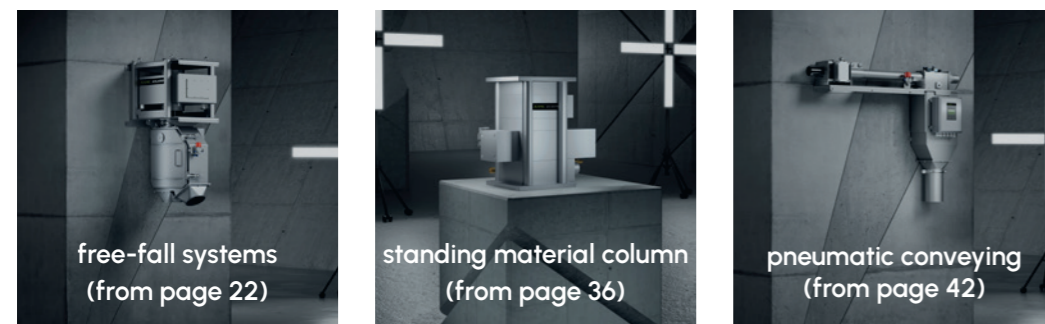

### 2 Magnets



### Material Management Systems





# Closing the Gap in the Plastic Recycling Loop

Plastic processors worldwide face the challenge of combining profitability with sustainability. The pressure to use resources efficiently while maintaining the highest quality standards is growing. One key strategy to address these demands is to close the gap in the material cycle. By employing modern sorting and recycling technologies, valuable raw materials can be recovered and reintegrated into the production process. This not only reduces the need for virgin materials but also minimizes waste and production rejects. At the same time, companies lower their costs and improve profitability. Sesotec supports processors with a broad portfolio along the entire production line with intelligent detection, analysis, and separation systems. This ensures economically viable production, even in dynamic market environments, while closing the material cycle—for a sustainable and profitable future.

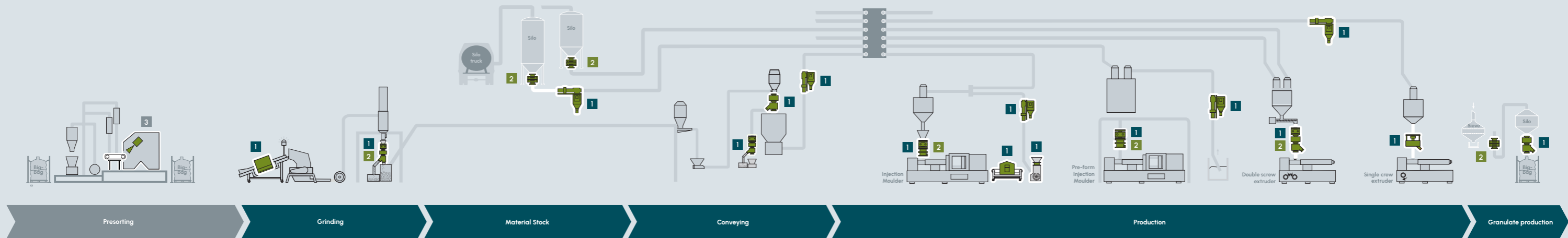

## 1 Metal Detectors & Metal Separators



conveyor belt application (from page 12)



free-fall application (from page 18)



free-fall systems (from page 22)

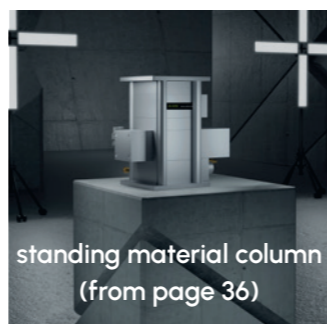

standing material column (from page 36)

## 2 Magnets



pneumatic conveying (from page 42)

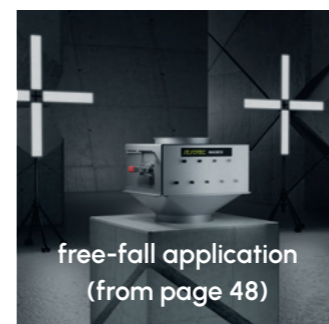

free-fall application (from page 48)



standing material column (from page 48)

## 3 Material Management Systems

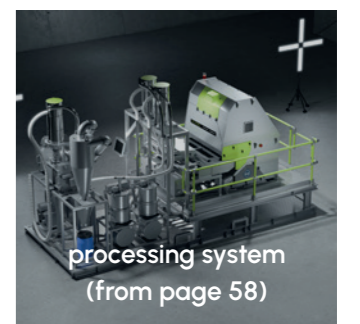

processing system (from page 58)

# SMART DATA MANAGEMENT

EXCELLENT SENSORS WITH ADDED VALUE

## Data Collection & Processing

High-quality and reliable hardware is the standard for secure production. The difference in maximizing profitability and ensuring a future-proof production and processing of plastics lies in networking and immediate data collection and processing, live during the production process. Added value comes from identifying new optimization potentials and controlling production processes.

### Speed.Tracking



Speed



GF



Learn more on page 44

More than just (hot) air:  
The airspeed within the closed pipe system is known. But how can the actual product speed be measured to optimally control the production process and minimize the incorrect ejection of good material? Through the innovative sensors and data acquisition of the GF.

### Monitoring.Package

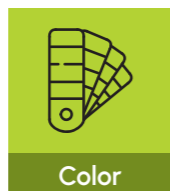

Color



Humidity



Temperature



PROTECTOR MEDICAL



Learn more on page 38

The sensor package ensures optimal ejection rates for applications with standing material columns in extrusion processes, injection molding, or blow molding. Anomalies are reliably detected, and plastic processing in terms of machine protection and product quality is elevated to a new level.

SOFTWARE AS A SERVICE

## Data analysis & visualization

How is it ensured that production processes and machines function correctly—and ideally around the clock? It's simple: by making all relevant machine data available. Anytime and anywhere. Sesotec's browser-based visualization software, Insight.WEB, is the first choice when it comes to transparency, production optimization, and control.

### Insight.WEB

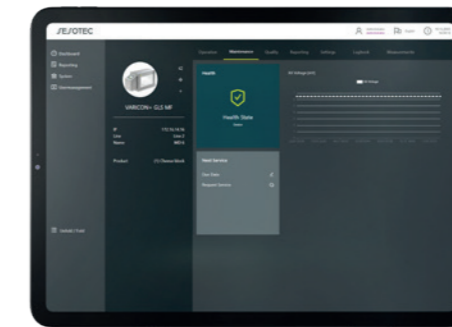
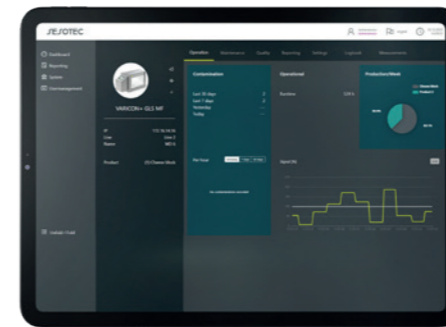

Insight.WEB is the visualization of the collected data from your Sesotec devices: Depending on the work area, all information is presented in clear graphics through dashboards such as Operation, Maintenance, Compliance, or Quality. Important production milestones are recorded and documented via PDF reports. Analyzing production efficiency and optimizing various influencing factors (e.g., supplier monitoring in the case of recurring higher rejection rates) has never been easier. Additionally, operations managers get an overview of specific device parameters such as temperature and transmitter/receiver voltage. The logbook is viewable, downloadable, and can be supplemented with additional comments. Each dashboard allows for different filter and view settings so that all information is displayed exactly as best suits the user.

**More control. Higher efficiency.  
Maximum profit.**

## 1 Metal Detectors

Sesotec metal detectors effectively protect against machine damage and production downtime, as well as complaints and recalls. Whether the contamination is made of iron, steel, stainless steel, or non-ferrous metals such as aluminum, copper, and brass, whether it is exposed or embedded in the product: our metal detection systems use inductive technology to detect all metallic foreign objects.

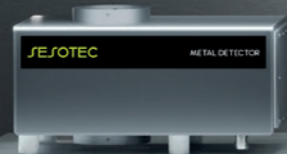

## Metal Separators 1

Sesotec metal separators not only detect all metallic foreign objects – but through the integrated separation unit, they also provide immediate protection against machine damage and production downtime. Whether the contamination is made of iron, steel, stainless steel, or non-ferrous metals such as aluminum, copper, and brass, whether it is exposed or embedded in the product: high-precision sensors minimize material loss during the ejection process.



# For conveyor belts and chutes

Tunnel and flat metal detectors are easily integrated into all production lines for piece goods and bulk materials. Tunnel metal detectors surround a conveyor belt, while flat metal detectors are installed below conveyor belts or chutes

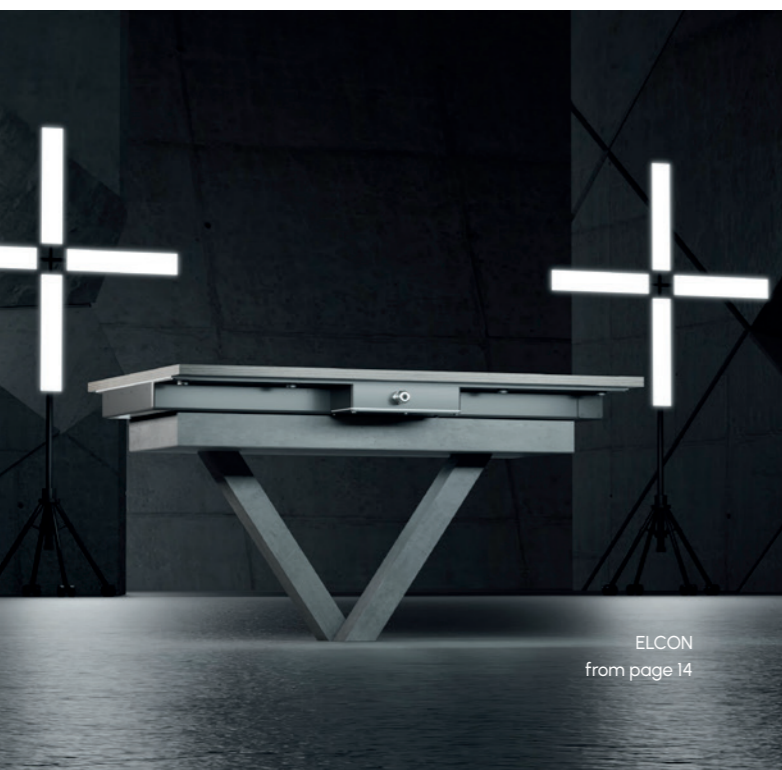

	ELCON	ELS	C-SCAN DLS	GLS
	page 14	page 14	page 16	page 17

## piece goods

	<100 mm trays, plastic components	✓	✓	✗	✓
	100 bis 1000 mm preforms, packaging material	✗	✗	✓	✓
	>1000 mm large boxes, baled goods, containers	✗	✗	✗	✓

## bulk materials

	<100 mm shredded material, regrind, pellets	✓	✓	✗	✓
	100 bis 1000 mm bottles, recycling material	✗	✗	✓	✓
	>1000 mm recycling material	✗	✗	✗	✓

## extrudates

	<100 mm foils, hides	✓	✓	✗	✓
	100 bis 1000 mm profiles, pipes	✗	✗	✓	✓
	>1000 mm pipes, profiles	✗	✗	✗	✓

# ELCON / ELS

Flat coil for the inspection of web materials, flat piece goods, and bulk materials with a flat conveying height



For web materials, flat piece goods, and bulk materials

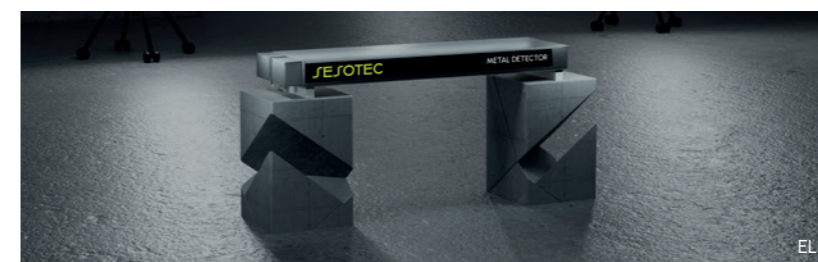

**Free consultation**  
<https://www.sesotec.com/contact>



## Auto-learn-function

Auto-learn-function or manual product compensation for optimal adaptation to the inherent conductivity of the product being examined, resulting in a lower false ejection rate



## Highest stability

Robust design also protects in challenging environmental conditions and prevents false ejections. Thus, you avoid the loss of good material



## IoT-Ready

- Networking with other system components is possible, whether via network cable or WLAN
- All common protocols available, such as OPC-UA or MQTT

## The essentials at a glance

- Touch width: 240 – 2800 mm
- Simplest installation through mounting rails
- Used in conveyor belts and material chutes
- Easy operation through the use of the robust Control Unit Primus+
- Ethernet interface (IoT-ready) as an option

## Your benefits

- Quality assurance: Consistent product quality, protection against complaints, and traceability through logbook functionality
- Process safety: Reliable and precise detection prevents downtime due to tool damage
- Cost-effectiveness: High line availability due to short installation time and reduced manual effort

Metal detectors for use by plastic processors and manufacturers must meet specific requirements:

- Detection of the smallest metal parts, even at larger diameters
- Low susceptibility to interference
- Easy and quick installation

## Technical data ELCON

Touch width	240–1390 mm
Detection accuracy	From Ø 2.50 mm FE and 3.00 mm V2A
Installation width	250–1400 mm
IP protection class	IP65
Product temperature	-10 °C to +80 °C

## Options

Interfaces options	Ethernet, WLAN, Profibus, Profi.NET
Available protocols for integration into the company network	OPC-UA, MQTT, Sesotec SSTPROT, Rest API (via COMGateway.Embedded and Insight.360)

## Technical data ELS

Nominal width	300–2800 mm
Detection accuracy	From Ø 1.30 mm FE and 2.20 mm V2A
Installation width	570–3070 mm
IP protection class	IP54
Product temperature	-10°C to +80°C

## Options

Interfaces options	Ethernet, WLAN, Profibus, Profi.NET
Available protocols for integration into the company network	OPC-UA, MQTT, Sesotec SSTPROT, Rest API (via COMGateway.Embedded and Insight.360)

# C-SCAN DLS

Split tunnel coil for the inspection of piece goods and bulk materials starting from 100 mm

from <b>2.5</b> mm	up to <b>300</b> kHz	up to <b>80</b> °C
Detection	Frequency	Product temp.

## Auto-learn-function

Auto-learn-function or manual product compensation for optimal adaptation to the inherent conductivity of the product being examined, resulting in a lower false ejection rate

## Easy installation

The detachable bottom part ensures the easiest installation in existing conveyor belt applications. You avoid costly modifications and can easily renew it

## IoT-Ready

- Networking with other system components is possible, whether via network cable or WLAN
- All common protocols available, such as OPC-UA or MQTT

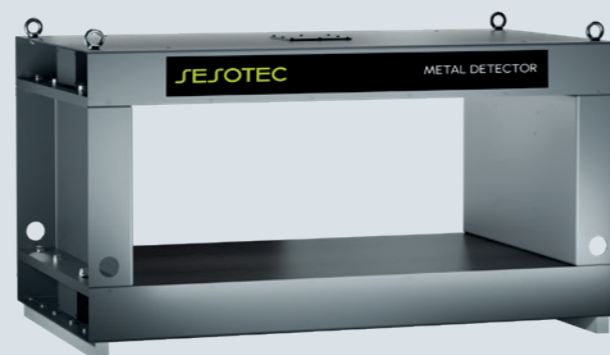

## Technical data

## C-SCAN DLS

Detection accuracy	From Ø 2.50 mm FE
Frequency bandwidth	Up to 300 kHz
IP protection class	IP54
Display size	Robust LCD display
Min./Max. tunnel size (DB x TB x DH)	500/300/150 up to 2280/2000/800
Min./Max. product size	200/100 mm up to 1900/700 mm
Ambient temperature	-10 °C up to +50 °C
Product temperature	-20 °C up to +80 °C
Conveyor belt speed	0.025 up to 2.0m/s

## Options

<b>GENIUS ONE</b>	Upgrade of the control unit for improved sensitivity
<b>Interfaces options</b>	Ethernet, WLAN, Profibus, Profi.NET
<b>Available protocols for integration into the company network</b>	OPC-UA, MQTT, Sesotec SSTPROT, Rest API (via COMGateway.Embedded and Insight.360)

# GLS

Tunnel coil for the inspection of piece goods and bulk materials on a conveyor belt or material chute with very good sensitivity

<b>1.1</b> mm	up to <b>300</b> kHz	up to <b>80</b> °C
Detection	Frequency	Product temp.

## GENIUS ONE Control Unit

- New user interface with touch display for the easiest operation
- Faster learning curve, fewer operational errors, and shorter operating times
- Cost and time savings through effective operating and service functions

## Highest flexibility

Perfect adaptation to customer-specific requirements through a closed coil system with over 300 different coil sizes

## IoT-Ready

- Networking with other system components is possible, whether via network cable or WLAN
- All common protocols available, such as OPC-UA or MQTT



## Technical data

## GLS

Detection accuracy	From Ø 1.06 mm V2A
Frequency bandwidth	Up to 300 kHz
IP protection class	IP65 (optional IP66/69K)
Display size	5"-color touch display
Min./Max. tunnel size (DB x DH)	50/25 up to 2800/250
Min./Max. product size	20/10 mm up to 2700/200 mm
Ambient temperature	-10 °C up to +50 °C
Product temperature	-20 °C up to +80 °C
Conveyor belt speed	0.02 up to 20.0 m/s

## Options

<b>Dual frequency</b>	Two frequencies for optimal detection performance with different products
<b>Interfaces options</b>	Ethernet, WLAN, Profibus, Profi.NET
<b>Available protocols for integration into the company network</b>	OPC-UA, MQTT, Sesotec SSTPROT, Rest API (via COMGateway.Embedded and Insight.360)

# For free-fall applications

Whether in piece form, powdered, fine, or coarse bulk material: Sesotec metal detection systems are the first choice for free-fall applications

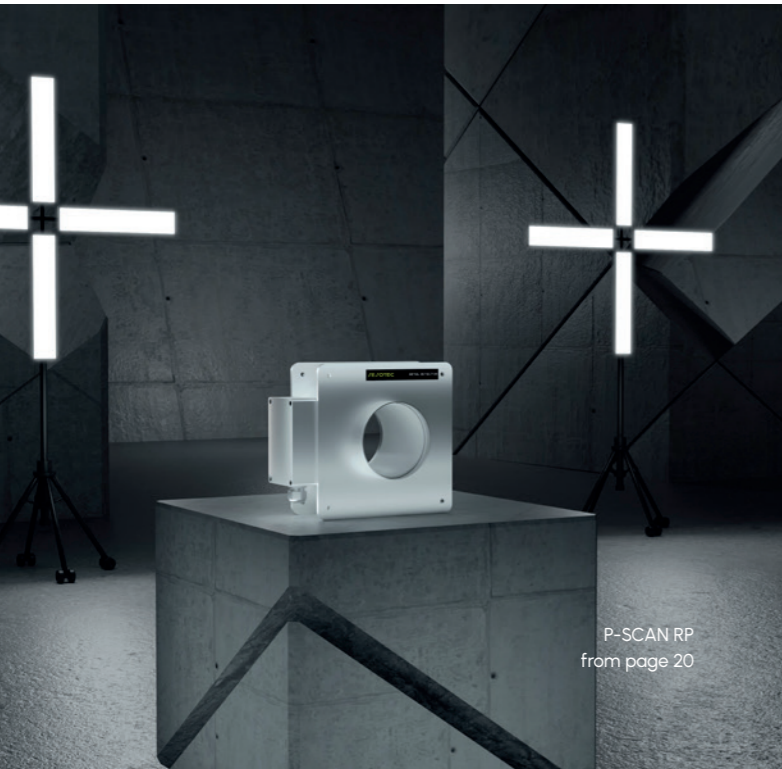

P-SCAN RP  
from page 20













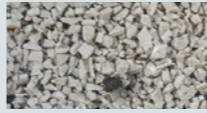

P-SCAN RS  
from page 20



P-SCAN RG  
from page 20

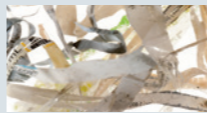
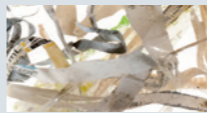

C-SCAN RP  
from page 20

METAL DETECTION	P-SCAN RP	P-SCAN RS	P-SCAN RG	C-SCAN RP
	page 20	page 20	page 20	page 20
 <b>granulate</b> (<math>\leq \varnothing 8 \text{ mm}</math>) well flowable, unless the material is resinous	✓	✓	✓	✓
 <b>regrind</b> (<math>\leq \varnothing 8 \text{ mm}</math>) moderate flowability, as long as only a small proportion of powder is contained	✓	✓	✓	✓
 <b>flakes</b> (<math>\leq \varnothing 14 \text{ mm}</math>, thinner than 1.5 mm) flexible, poorly flowable, bridging	✓	✓	✓	✓
 <b>PET-flakes</b> (<math>\leq \varnothing 14 \text{ mm}</math>, thinner than 1.5 mm) flexible, poorly flowable, bridging, abrasive	✓	✓	✓	✓
 <b>chips</b> (>math>\varnothing 10 \text{ mm}</math>) poorly flowable due to large size	✓	✓	✓	✓
 <b>shredded material</b> (>math>\varnothing 10 \text{ mm}</math>) poorly flowable due to size and thickness	✓	✓	✓	✓
 <b>powder</b> (<math>\leq \varnothing 1 \text{ mm}</math>) poorly flowable, powder accumulates in the corners and edges of the separation unit	✓	✓	✓	✗
 <b>powder</b> (moisture absorbing, <math>\leq \varnothing 1 \text{ mm}</math>) clumping occurs upon contact with moisture	✓	✓	✓	✗
 <b>foil scraps</b> poorly flowable, have the property of accumulating over the ejection flap	✓	✓	✓	✓
 <b>fibers</b> (shorter than 8 mm) moderate flowability, can accumulate in the metal separator	✓	✓	✓	✓
 <b>fibers</b> (longer than 8 mm) moderate flowability, can become over the ejection flap	✓	✓	✓	✓
 <b>glass fibers</b> (shorter than 8 mm, share <math>\leq 20\%</math>) moderately flowable, abrasive	✓	✓	✓	✓
 <b>glass fibers</b> (shorter than 8 mm, share <math>\geq 20\%</math>) moderately flowable, abrasive	✓	✓	✓	✓
 <b>carbon fibers</b> (shorter than 8 mm) moderately flowable conductive = product effect!	✓	✓	✓	✓

FOR FREE-FALL APPLICATIONS – METAL DETECTION

# P-SCAN RP / RS / RG C-SCAN RP

For the inspection of free-falling bulk materials or small piece goods

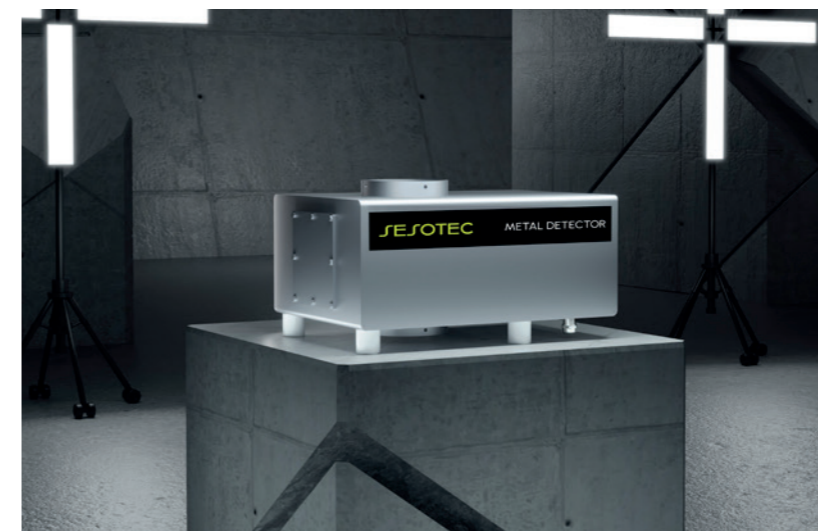

For free-falling bulk materials or small piece goods

Free consultation  
<https://www.sesotec.com/contact>



## Easiest installation

Nominal widths tailored to common pipe diameters ensure the easiest installation in existing piping systems. This avoids costly modifications and allows for easy renewal

## Interference immunity

Compact design and electrotechnical filters increase interference immunity against environmental influences



## Increased user comfort

Easy menu navigation on the GENUIS ONE through the touch display or the robust LCD display variant of the PRIMUS+ ensures quick orientation within the menu structure

## The essentials at a glance

- Highest detection accuracy
- Nominal width: 30–600 mm
- Easiest installation through mounting kits
- Used in vertical and horizontal conveyor lines
- Easy operation through the use of the Control Unit PRIMUS+ or Genuis ONE with logbook function
- Ethernet interface (IoT-ready) as an option

## Your benefits:

- Quality assurance: Consistent product quality, protection against complaints, and traceability through logbook functionality
- Process safety: Reliable and precise detection prevents downtime due to tool damage
- Cost-effectiveness: High line availability due to short installation time and reduced manual effort

Metal detectors for use by plastic processors and manufacturers must meet specific requirements:

- Detection of the smallest metal parts, even at larger diameters
- Low susceptibility to interference
- Easy and quick installation

## Technical data

	 P-SCAN RP	 P-SCAN RS	 P-SCAN RG	 C-SCAN RP
<b>Nominal widths</b>	40–265 mm	100–450 mm	30–600 mm	300/250 mm
<b>Detection accuracy</b>	From Ø 0.30 mm FE and 0.60 mm V2A	From Ø 0.60 mm FE and 1.20 mm V2A	From Ø 0.20 mm FE and 0.30 mm V2A	Ø 8.0 mm FE and 9.0 mm V2A
<b>Frequency bandwidth</b>	up to 300 kHz	up to 300 kHz	up to 600 kHz	up to 300 kHz
<b>IP protection class</b>	IP65	IP65	IP65	IP65
<b>Number of available sizes</b>	11	11	17	1, expandable to other mill shafts
<b>Installation height</b>	130–250 mm	150–290 mm	160–620 mm	160 mm
<b>Ambient temperature</b>	-10°C up to +50°C	-10°C up to +50°C	-10°C up to +50°C	-10°C up to +50°C
<b>Product temperature</b>	-10°C up to +80°C	-10°C up to +80°C	-10°C up to +80°C	-10°C up to +50°C
<b>Conveying speed</b>	0.3–20 m/s best sensitivity up to 25 m/s max. possible	0.1–8 m/s best sensitivity up to 25 m/s max. possible	0.1–5 m/s best sensitivity up to 25 m/s max. possible	1.0–3.0 m/s

## Options

<b>Interfaces options</b>	Ethernet, WLAN, USB, Profibus, Profi.NET
<b>Available protocols for integration into the company network</b>	OPC-UA, MQTT, Sesotec SSTPROT, Rest API (via COMGateway, Embedded and Insight.360)

# For free-fall applications

Sesotec free-fall systems are easy and quick to integrate into existing pipelines. With innovative HRF technology, they have the highest sensitivity to all metals and automatically eject metallic foreign objects



RAPID PRO-SENSE SERIES  
from page 26









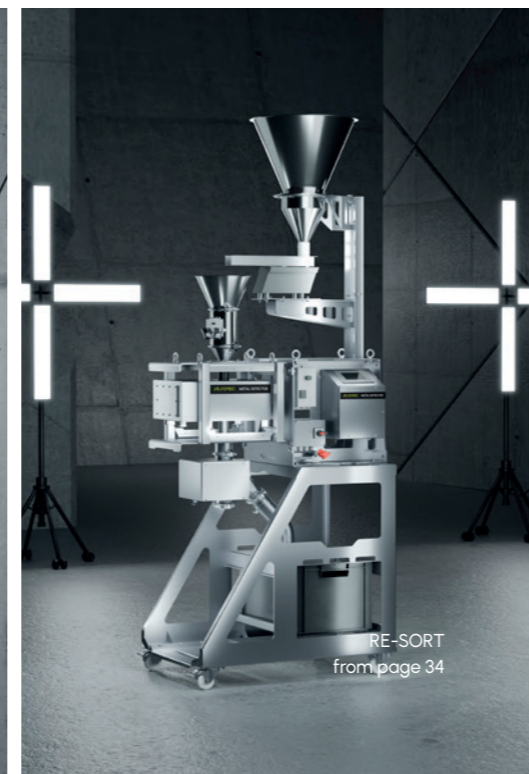







RAPID DUAL  
from page 25



RAPID VARIO-FS  
from page 24



RE-SORT  
from page 34

METAL SEPARATION	RAPID VARIO-FS	RAPID DUAL	RAPID PRO-SENSE				RE-SORT
	page 24	page 25	4	5	6	8	page 34
 <b>granulate</b> (<math>< \varnothing 8 \text{ mm}</math>) well flowable, unless the material is resinous	✓	✓	✓	✓	✓	✓	✓
 <b>regrind</b> (<math>< \varnothing 8 \text{ mm}</math>) moderate flowability, as long as only a small proportion of powder is contained	✓	✗	✓	✓	✗	✓	✓
 <b>flakes</b> (<math>< \varnothing 14 \text{ mm}</math>, thinner than 1.5 mm) flexible, poorly flowable, bridging	✓	✓	✓	✗	✓	✓	✓
 <b>PET-flakes</b> (<math>< \varnothing 14 \text{ mm}</math>, thinner than 1.5 mm) flexible, poorly flowable, bridging, abrasive	✓	✓	✓	✗	✓	✓	✓
 <b>chips</b> (>math>> \varnothing 10 \text{ mm}</math>) poorly flowable due to large size	✗	✓	✗	✗	✓	✓	✗
 <b>shredded material</b> (>math>> \varnothing 10 \text{ mm}</math>) poorly flowable due to size and thickness	✗	✗	✗	✗	✓	✓	✗
 <b>powder</b> (<math>< \varnothing 1 \text{ mm}</math>) poorly flowable, powder accumulates in the corners and edges of the separation unit	✓	✗	✗	✓	✗	✓	✗
 <b>powder</b> (moisture absorbing, <math>< \varnothing 1 \text{ mm}</math>) clumping occurs upon contact with moisture	✗	✗	✗	✓	✗	✗	✗
 <b>foil scraps</b> poorly flowable, have the property of accumulating over the ejection flap	✗	✓	✗	✗	✓	✓	✗
 <b>fibers</b> (shorter than 8 mm) moderate flowability, can accumulate in the metal separator	✗	✓	✗	✗	✓	✓	✗
 <b>fibers</b> (longer than 8 mm) moderate flowability, can become over the ejection flap	✗	✓	✗	✗	✓	✓	✗
 <b>glass fibers</b> (shorter than 8 mm, share <math>< 20\%</math>) moderately flowable, abrasive	✗	✓	✗	✗	✓	✓	✗
 <b>glass fibers</b> (shorter than 8 mm, share >math>\ge 20\%</math>) moderately flowable, abrasive	✗	✓	✗	✗	✓	✓	✗
 <b>carbon fibers</b> (shorter than 8 mm) moderately flowable conductive = product effect!	✗	✓	✗	✗	✓	✓	✗

# RAPID VARIO-FS

Entry-level model for the inspection of bulk materials in free-fall conveyor lines

<b>Quick Flap</b>	up to <b>69,000</b> l/h	up to <b>8</b> mm
Mechanics	Throughput	Grain size

## Auto-learn-function

Auto-learn function or manual product compensation for optimal adaptation to the inherent conductivity of the product being examined, resulting in a lower false ejection rate

## Simplified design

Compact design ensures low installation height and allows for use in challenging environments. Complicated modifications are avoided

## Quick Flap

- Safe ejection of metallic contaminants starting from 0.3 mm
- Low loss of good material



## Technical data RAPID VARIO-FS

Nominal widths	30–250 mm
Detection accuracy	From Ø 0.30 mm FE and 0.60 mm V2A
Installation height	442–1092 mm
IP protection class	IP65
Throughput capacity	Max. 69,000 l/h
Free fall height	500 mm (optional up to 1 m)
Particle size	Ball Ø <8 mm
Particle shape	Granules, granulate, flakes
Ejection mechanism	Square mechanics with quick flap ejection
Product temperature	Max. +80 °C
Conveying pressure	Pressureless (free fall)
Flowability	Medium to good

## Options

# RAPID DUAL

For the inspection of coarse, fluffy, and fibrous bulk materials in free-fall conveyor lines

<b>Double Flap</b>	up to <b>180,000</b> l/h	up to <b>20</b> mm
Mechanics	Throughput	Grain size

## Auto-learn-function

Auto-learn function or manual product compensation for optimal adaptation to the inherent conductivity of the product being examined, resulting in a lower false ejection rate

## Easy installation

For particularly easy installation, the device is available in all common nominal widths. Thus, no elaborate modifications are necessary. The wide diameters help to easily control large quantities of bulk materials

## Double flap system

- Reliable ejection of fibrous and chunkier bulk materials using a double flap
- Low loss of good material



## Technical data RAPID DUAL

Nominal widths	150–400 mm
Detection accuracy	From Ø 1.20 mm FE and 1.80 mm V2A
Installation height	831–1870 mm
IP protection class	IP65
Throughput capacity	Max. 180,000 l/h
Free fall height	700 mm (optional up to 1 m)
Particle size	Ø <20 mm, Flakes up to 100 × 100 × 10 mm
Particle shape	Flakes, fibrous and coarse bulk materials
Ejection mechanism	Double flap system
Product temperature	Max. +80 °C
Conveying pressure	Pressureless (free fall)
Flowability	Medium to good

## Options

Improved wear protection	For reduced downtime
Interfaces options	Ethernet, WLAN, Profibus, Profi.NET
Available protocols for integration into the company network	OPC-UA, MQTT, Sesotec SSTPROT, Rest API (via COMGateway, Embedded and Insight.360)

FOR FREE-FALL APPLICATIONS – METAL SEPARATION

# RAPID PRO-SENSE 4

High-end model for the detection of bulk materials in free-fall conveying lines

<b>Quick Flap</b>	up to <b>69,000</b> l/h	up to <b>8</b> mm
Mechanics	Throughput	Grain size

## Auto-learn function

Auto-learn-function or manual product compensation for optimal adaptation to the intrinsic conductivity of the product under investigation and consequently a lower false rejection rate

## Easy Clean swivel device

For particularly easy cleaning, the RAPID PRO-SENSE 4 has an Easy Clean swiveling device for the separating unit. After the product flow has been stopped, the separation unit can be swung to the side – for easy access to the separation and detection unit. A built-in safety switch deactivates the compressed air supply in the meantime

## Quick Flap

- Reliable rejection of metallic contaminants from 0.3 mm
- Low loss of good material

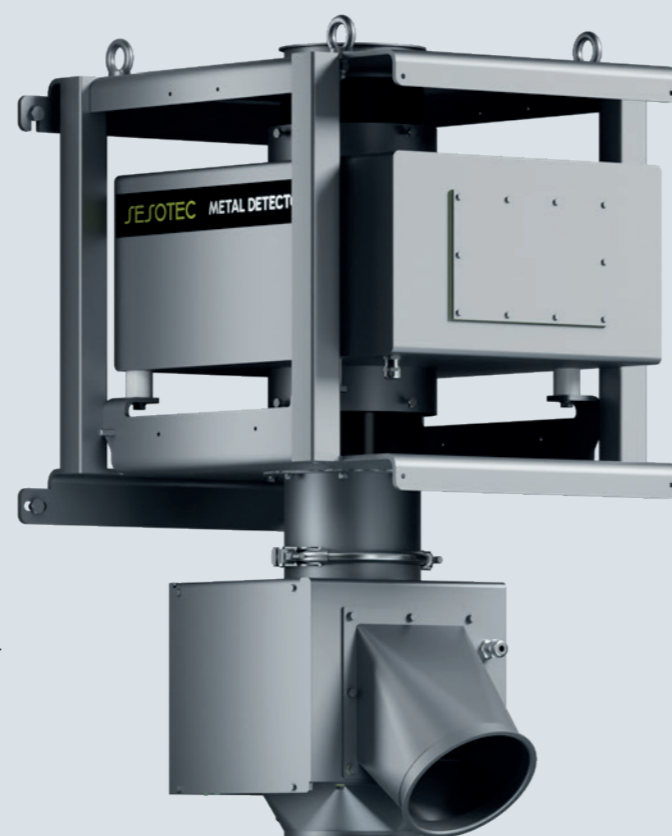

For granular bulk materials in free fall

**Free consultation**

<https://www.sesotec.com/contact>

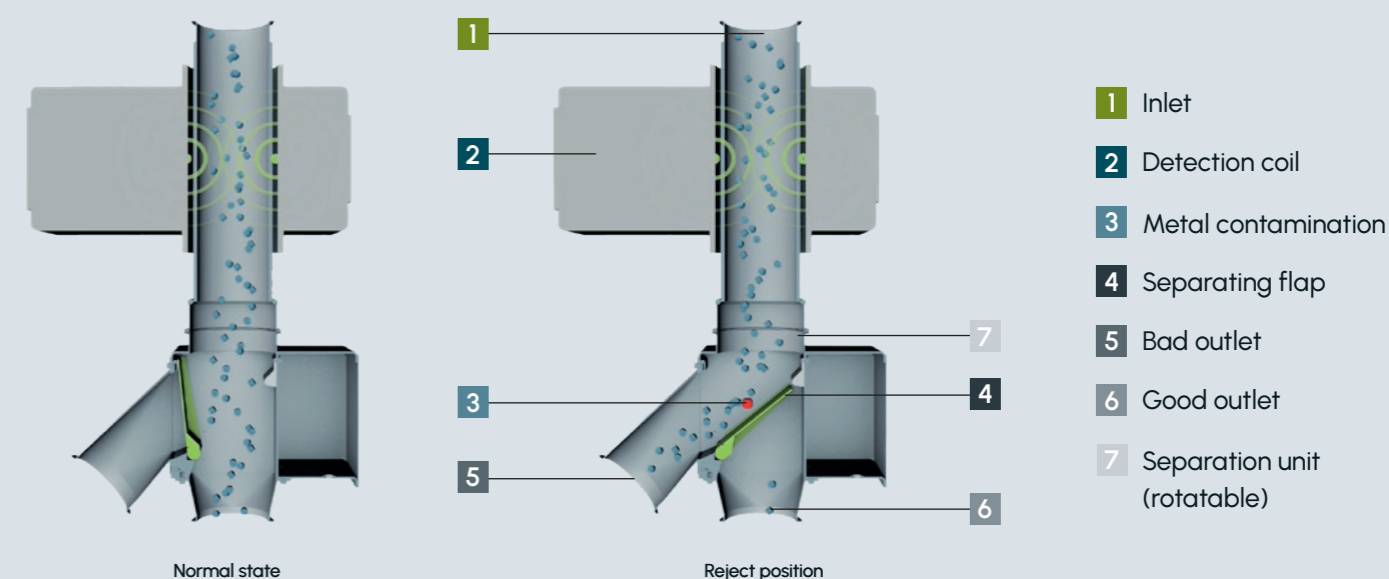

## Technical data

## RAPID PRO-SENSE 4

## Options

Nominal widths	30–250 mm
Detection accuracy	From Ø 0.30 mm FE and 0.40 mm V2A
Installation height	703–1431 mm
IP protection class	IP65
Throughput	Max. 69,000 l/h
Free fall height	500 mm (optional up to 1 m)
Grain size	Ball Ø <8mm
Grain shape	Grains, granules, regrind, pellets
Reject mechanism	Angular mechanism with Quick Flap rejection
Product temperature	Max. +80 °C
Delivery pressure	Pressureless (free fall)
Flowability	Medium to good

<b>Automatic function test module</b>	For continuous function testing without additional effort
<b>Interfaces IP options</b>	Ethernet, WLAN, USB, Profibus, Profi.NET
<b>Available protocols for integration into the company network</b>	OPC-UA, MQTT, Sesotec SSTPROT, Rest API (via COMGateway.Embedded and Insight.360)

FOR FREE-FALL APPLICATIONS – METAL SEPARATION

# RAPID PRO-SENSE 5

For testing fine-grained and powdery bulk materials in free-fall conveying lines with high hygienic requirements

<b>Quick Flap</b>	up to <b>69,000</b> l/h	up to <b>8</b> mm
Mechanics	Throughput	Grain size

## High-resolution frequency package

Highest detection accuracy through RF coil ensures purest material

## Easy Clean swivel device

For particularly easy cleaning, the RAPID PRO-SENSE 5 has an Easy Clean swiveling device for the separating unit. After the product flow has been stopped, the separation unit can be swung to the side – for easy access to the separation and detection unit. A built-in safety switch deactivates the compressed air supply in the meantime

## Round Quick Flap

- Safe ejection of metallic contaminants starting from 0.3 mm
- Low loss of good material
- Prevention of residues through a dead space-free design using a round ejection mechanism

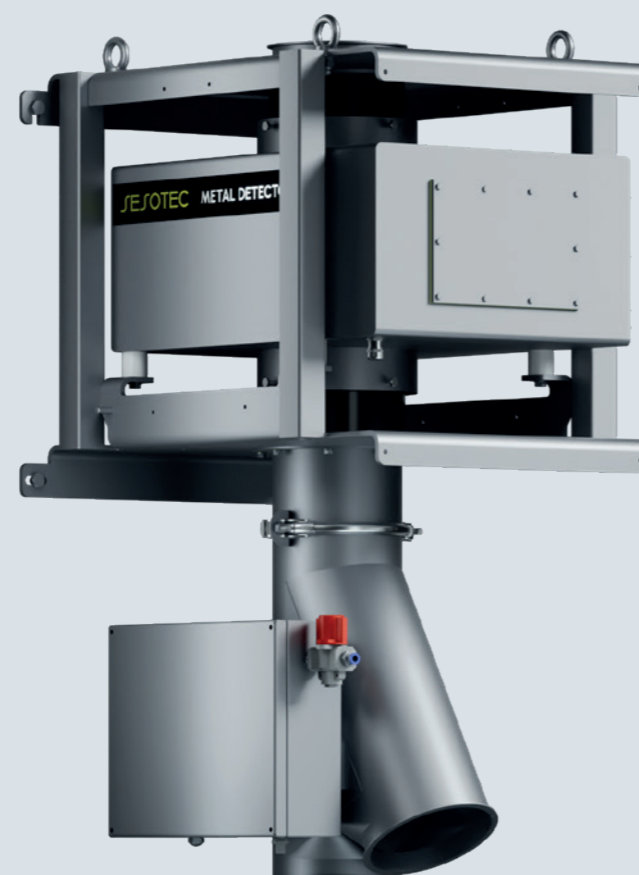

For fine-grained and powdery bulk materials in free fall

**Free consultation**

<https://www.sesotec.com/contact>

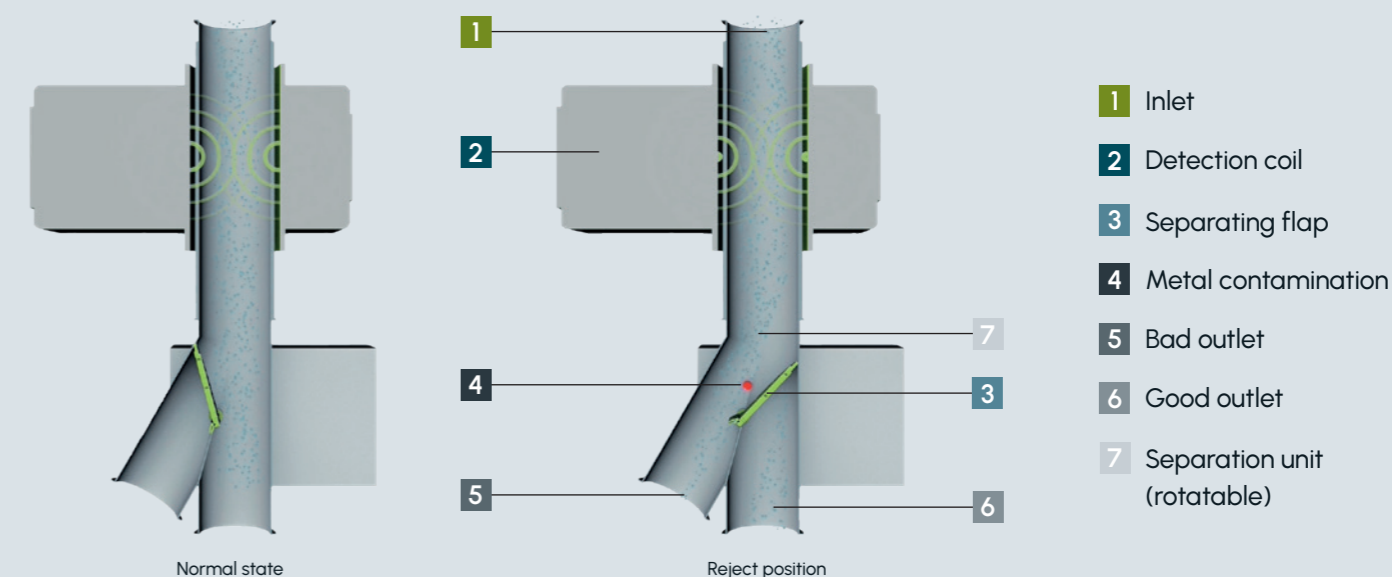

## Technical data

## RAPID PRO-SENSE 5

## Options

Nominal widths	50–250 mm
Detection accuracy	From Ø 0.30 mm FE and 0.50 mm V2A
Installation height	709–1494 mm
IP protection class	IP65
Throughput	Max. 69,000 l/h
Free fall height	500 mm (optional up to 1 m)
Grain size	Ball Ø <8mm
Grain shape	Powder, fine-grained bulk materials
Reject mechanism	Round mechanism (no powder deposits) with Quick Flap rejection
Product temperature	Max. +80 °C
Delivery pressure	Pressureless (free fall)
Flowability	Medium to good

<b>Automatic function test module</b>	For continuous function testing without additional effort
<b>Interfaces options</b>	Ethernet, WLAN, USB, Profibus, Profi.NET
<b>Available protocols for integration into the company network</b>	OPC-UA, MQTT, Sesotec SSTPROT, Rest API (via COMGateway.Embedded and Insight.360)

FOR FREE-FALL APPLICATIONS – METAL SEPARATION

# RAPID PRO-SENSE 6

For testing coarse-grained, flaky, fibrous and humid bulk materials in free-fall conveying lines with high hygienic requirements

Swivel funnel	up to <b>69,000</b> l/h	up to <b>20</b> mm
Mechanics	Throughput	Grain size

## High-resolution frequency package

Highest detection accuracy through RF coil ensures purest material

## Auto-learn-function

Auto-learn function or manual product compensation for optimal adaptation to the inherent conductivity of the product being examined, resulting in a lower false ejection rate

## Faster and easier access

- Tool-free access to the mechanics through a cleaning flap
- Optional washing nozzles allow for cleaning without personnel involvement



For coarse-grained, flaky, fibrous and moist bulk materials in free fall

**Free consultation**

<https://www.sesotec.com/contact>

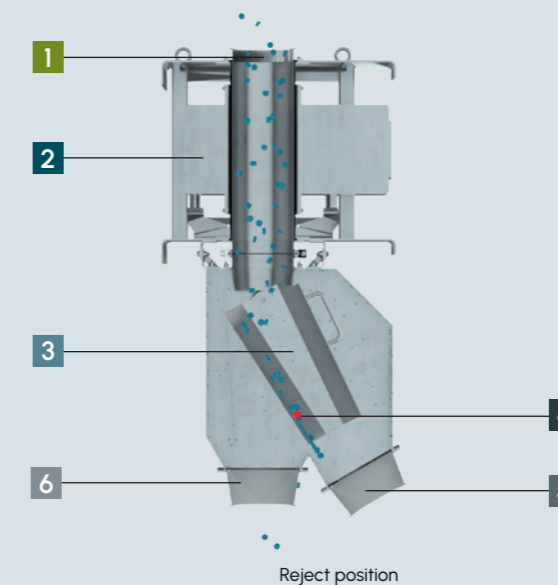
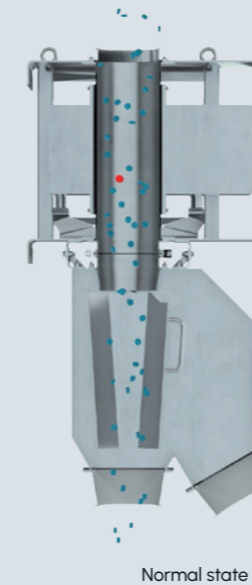

- 1 Inlet
- 2 Detection coil
- 3 Swivel funnel
- 4 Metal contamination
- 5 Bad outlet
- 6 Good outlet

## Technical data

## RAPID PRO-SENSE 6

## Options

Nominal widths	50–250 mm
Detection accuracy	From Ø 0.30 mm FE and 0.50 mm V2A
Installation height	991–1572 mm
IP protection class	IP65
Throughput	Max. 69,000 l/h
Free fall height	500 mm (optional up to 1 m)
Grain size	Ø <20mm, but also fibrous and lumpy
Grain shape	Fine-grained bulk materials, granules, fibres, flakes
Reject mechanism	Funnel reject mechanism with cleaning opening
Product temperature	Max. +80 °C
Delivery pressure	Pressureless (free fall)
Flowability	Medium to good

<b>Automatic function test module</b>	For continuous function testing without additional effort
<b>Interfaces options</b>	Ethernet, WLAN, USB, Profibus, Profi.NET
<b>Available protocols for integration into the company network</b>	OPC-UA, MQTT, Sesotec SSTPROT, Rest API (via COMGateway.Embedded and Insight.360)

# RAPID PRO-SENSE 8

For testing powdery, fibrous and lumpy bulk materials in free-fall conveying lines with high hygienic requirements

<b>Swivel funnel</b>	up to <b>69,000</b> l/h	up to <b>20</b> mm
Mechanics	Throughput	Grain size

## High-resolution frequency package

Highest detection accuracy through RF coil ensures purest material

## Auto-learn-function

Auto-learn function or manual product compensation for optimal adaptation to the inherent conductivity of the product being examined, resulting in a lower false ejection rate

## Swivel funnel

- Reliable ejection of fibrous and chunkier bulk materials using a swivel funnel
- Dust-tight design to prevent leakage through sealing
- Reduced wear on mechanics through ejection in the direction of the product flow



For coarse-grained, flaky, fibrous and moist bulk materials in free fall

## Free consultation

<https://www.sesotec.com/contact>

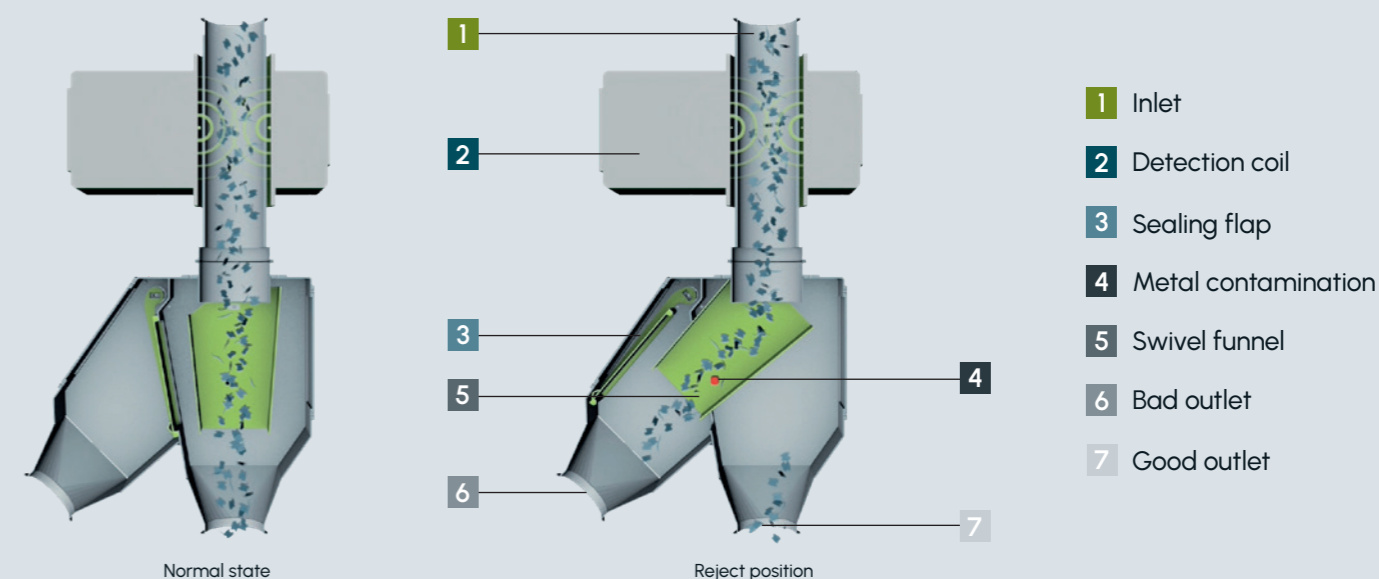

## Technical data

## RAPID PRO-SENSE 8

## Options

Nominal widths	50–250 mm
Detection accuracy	From Ø 0.30 mm FE and 0.50 mm V2A
Installation height	908–1402 mm
IP protection class	IP65
Throughput	Max. 69,000 l/h
Free fall height	500 mm (optional up to 1 m)
Grain size	Ø <20mm, but also fibrous and lumpy
Grain shape	Powder, fine-grained bulk materials, granules, fibres, flakes
Reject mechanism	Hopper reject mechanism with dust-tight reject outlet
Product temperature	Max. +80 °C
Delivery pressure	Pressureless (free fall)
Flowability	Good, medium, bad

<b>Automatic function test module</b>	For continuous function testing without additional effort
<b>Interfaces options</b>	Ethernet, WLAN, USB, Profibus, Profi.NET
<b>Available protocols for integration into the company network</b>	OPC-UA, MQTT, Sesotec SSTPROT, Rest API (via COMGateway.Embedded and Insight.360)

FOR FREE-FALL APPLICATIONS – METAL SEPARATION

# RE-SORT

For the recovery of already ejected good material, for granulate and regrind

Quick flap	up to <b>2000</b> l/h	up to <b>8</b> mm
Mechanics	Throughput	Particel size

## Increased material recovery

With the RE-SORT, up to 98% of good material can be recovered. This reduces your loss of good material to a minimum and maximizes the utilization of your systems

## Easy traceability

All common network connections are feasible, whether via Wi-Fi or hardwired. Established protocols for data communication are available, such as MQTT or OPC-UA

## Modular design

For every application location, there is a concept, whether as a fixed wall-mounted unit or mobile on wheels. By using our extractor, magnetic dust is also filtered, and with the help of the vibrating conveyor, continuous operation is ensured

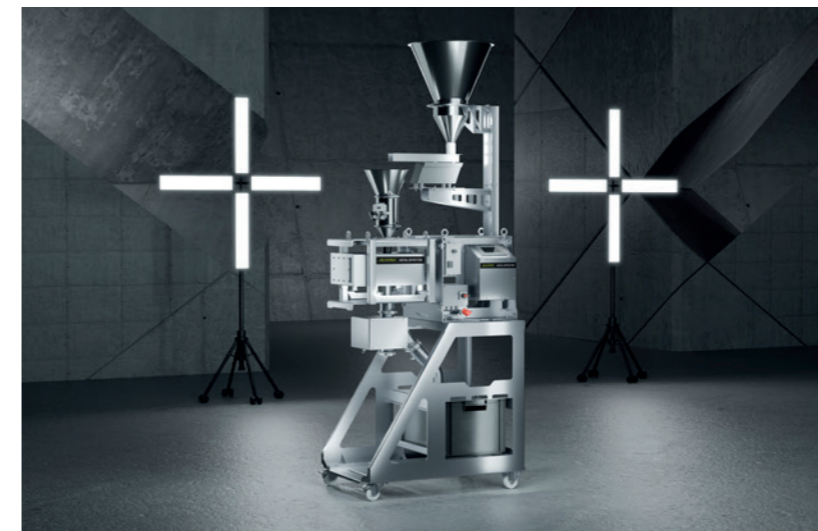

For granulates and regranulates as well as regrind

**Free consultation**

<https://www.sesotec.com/contact>

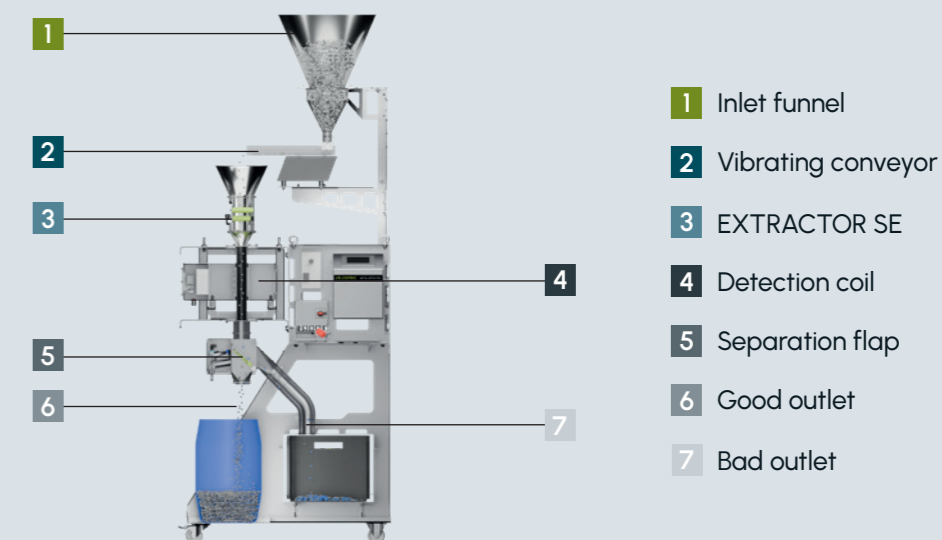

## Technical data

## RE-SORT

Nominal widths	50 mm
Detection accuracy	From Ø 0.30 mm FE and 0.50 mm V2A
Installation height	862–2402 mm
IP protection class	IP54
Throughput capacity	Max. 2000 l/h
Free fall height	500 mm
Particle size	Ø <8 mm
Particle shape	Granulate, regranulate, regrind
Ejection mechanism	Quick Flap
Product temperature	Max. +80 °C
Conveying pressure	Pressureless (free fall)
Flowability	Medium to good

## Options

<b>Easy Clean version</b>	For easy cleaning
<b>Interfaces options</b>	Ethernet, WLAN, USB, Profibus, Profi.NET
<b>Available protocols for integration into the company network</b>	OPC-UA, MQTT, Sesotec SSTPROT, Rest API (via COMGateway.Embedded and Insight.360)

# For material columns

Sesotec metal separators remove the smallest metal particles that would lead to costly disruptions in injection molding, extrusion and blow molding in the plastic melt



PROTECTOR  
from page 38

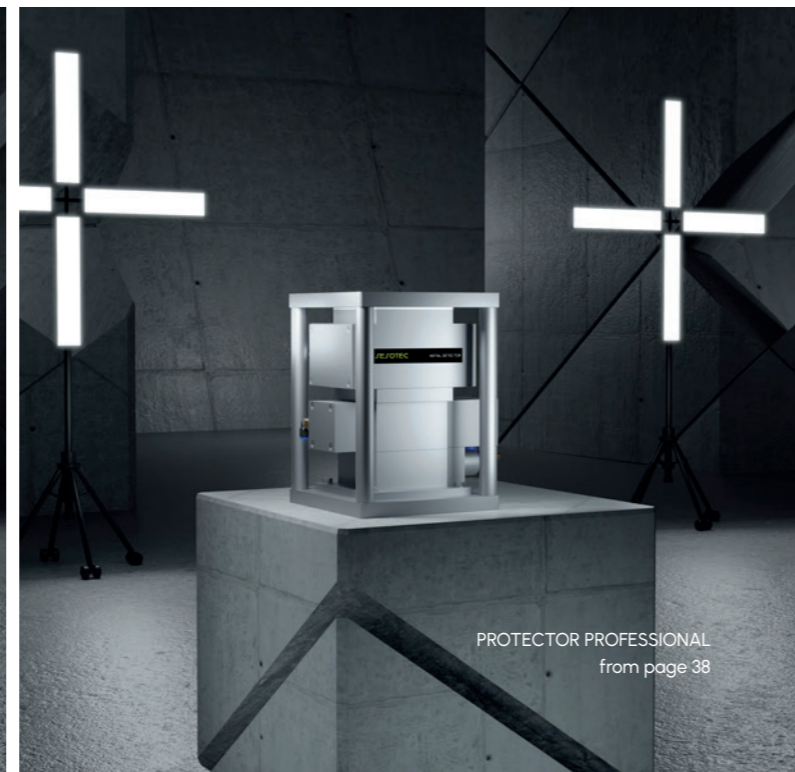



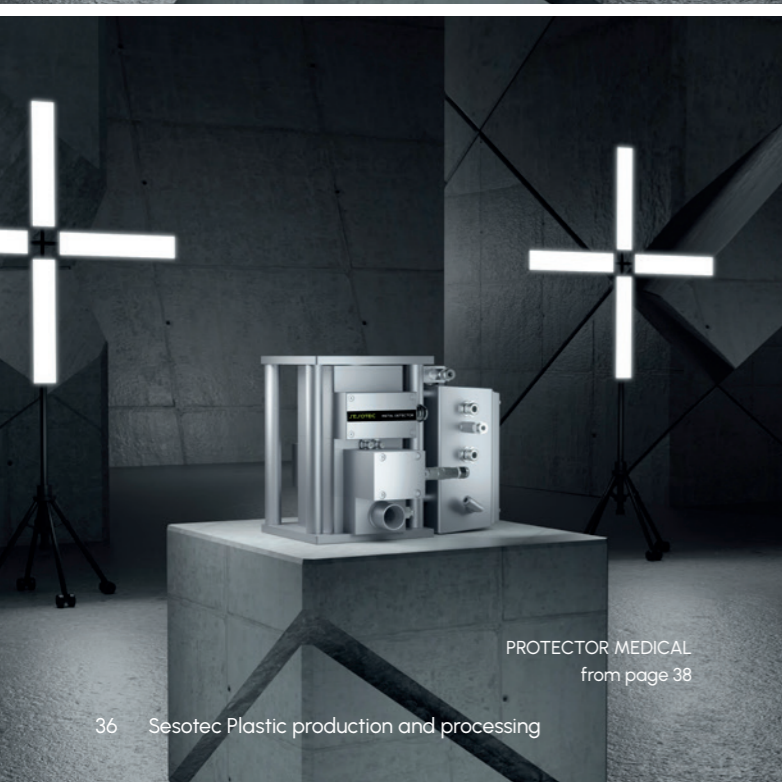



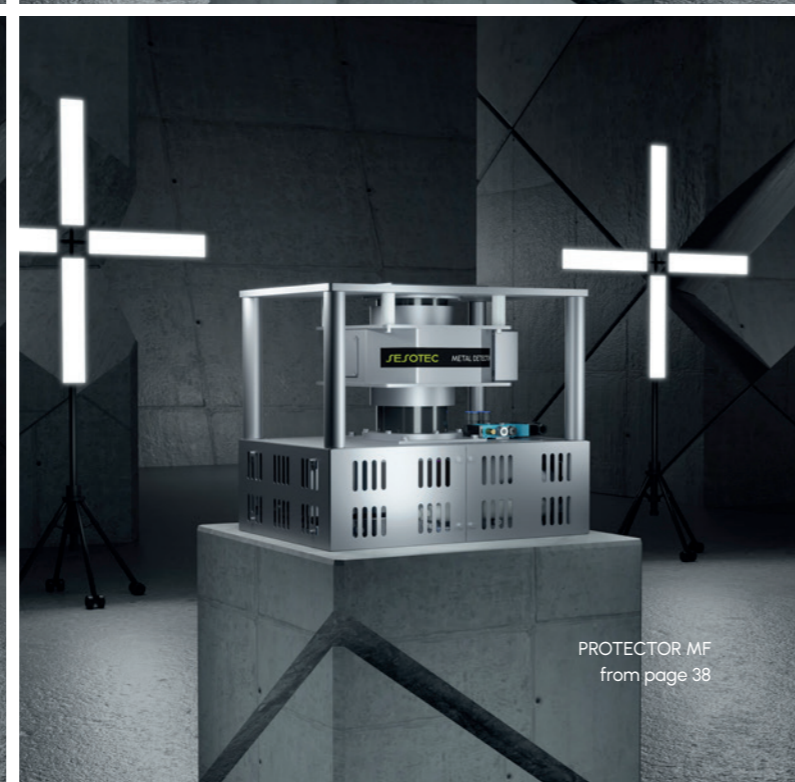



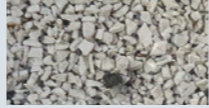

PROTECTOR PROFESSIONAL  
from page 38

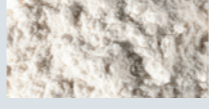
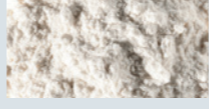

PROTECTOR MEDICAL  
from page 38

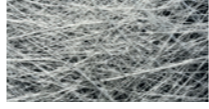
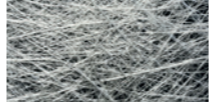

PROTECTOR MF  
from page 38

	PROTECTOR	PROTECTOR PROFESSIONAL	PROTECTOR MEDICAL	PROTECTOR MF
	page 38	page 38	page 38	page 38
 <b>granulate</b> (<math>< \varnothing 8 \text{ mm}</math>) well flowable, unless the material is resinous	✓	✓	✓	✓
 <b>regrind</b> (<math>< \varnothing 8 \text{ mm}</math>) moderate flowability, as long as only a small proportion of powder is contained	✓	✓	✗	✓
 <b>flakes</b> (<math>< \varnothing 14 \text{ mm}</math>, thinner than 1,5 mm) flexible, poorly flowable, bridging	✗	✗	✗	✓
 <b>PET-flakes</b> (<math>< \varnothing 14 \text{ mm}</math>, thinner than 1,5 mm) flexible, poorly flowable, bridging, abrasive	✗	✗	✗	✓
 <b>chips</b> (>math>> \varnothing 10 \text{ mm}</math>) poorly flowable due to large size	✗	✗	✗	✗
 <b>shredded material</b> (>math>> \varnothing 10 \text{ mm}</math>) poorly flowable due to size and thickness	✗	✗	✗	✗
 <b>powder</b> (<math>< \varnothing 1 \text{ mm}</math>) poorly flowable, powder accumulates in the corners and edges of the separation unit	✗	✗	✗	✓
 <b>powder</b> (moisture absorbing, <math>< \varnothing 1 \text{ mm}</math>) clumping occurs upon contact with moisture	✗	✗	✗	✓
 <b>foil scraps</b> poorly flowable, have the property of accumulating over the ejection flap	✗	✗	✗	✓
 <b>fibers</b> (shorter than 8 mm) moderate flowability, can accumulate in the metal separator	✗	✗	✗	✓
 <b>fibers</b> (longer than 8 mm) moderate flowability, can become over the ejection flap	✗	✗	✗	✓
 <b>glass fibers</b> (shorter than 8 mm, share <math>< 20\%</math>) moderately flowable, abrasive	✓	✓	✗	✓
 <b>glass fibers</b> (shorter than 8 mm, share <math>\ge 20\%</math>) moderately flowable, abrasive	✓	✓	✗	✓
 <b>carbon fibers</b> (shorter than 8 mm) moderately flowable conductive = product effect!	✗	✗	✗	✓

FOR MATERIAL COLUMNS

# PROTECTOR / MF/ PROFESSIONAL / MEDICAL

For the inspection of slowly moving material columns on injection molding machines, extruders, and blow molding machines



For slowly moving material columns

Free consultation  
<https://www.sesotec.com/contact>



## Last Chance Check point

Optimal timing for the ejection of contaminants at the material inlet, thus directly before the most sensitive components

## Interference immunity

Compact design and electrotechnical filters increase interference immunity against environmental influences

## Venturi ejection

Vertical ejection using a Venturi nozzle reduces the installation height



## The essentials at a glance

- Highest Detection accuracy
- Nominal width: 30–150 mm
- Separation without mechanical wear parts
- Easy operation through the use of the Control Unit PRIMUS+ with logbook function
- Ethernet interface (IoT-ready) as a function

## Your benefits

- Quality assurance: Consistent product quality, protection against complaints, and traceability through logbook functionality
- Process safety: Reliable and fast cleaning even in complex installation situations and reproducible cleaning processes.
- Cost-effectiveness: High line availability due to short cleaning times and reduced manual effort

Metal separators for use by plastic processors must meet specific requirements:

- Detection of the smallest metal parts, even at larger diameters
- Frequent material changes
- Easy and quick installation
- Use with abrasive materials

## Technical data

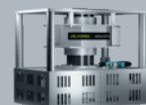
	 PROTECTOR	 PROTECTOR PROFESSIONAL	 PROTECTOR MEDICAL	 PROTECTOR MF
<b>Application</b>	Granulate, regrind Good to medium flowability Dry, moist, Non-abrasive	Granulate, regrind Good to medium flowability Dry, moist, Non-abrasive	Granulate, regrind Good to medium flowability Dry, moist, Non-abrasive	Granulate, regrind Good to medium flowability Dry, moist, Non-abrasive
<b>Particle size</b>	Ø <6 mm at NW 30/40 Ø <8 mm at NW 50/60	Ø <6 mm	Ø <6 mm	Ø <10 mm
<b>Pressure load</b>	500 kg centrally	500 kg centrally	500 kg centrally	500 kg centrally, with reinforcement even more
<b>Installation height</b>	270–324 mm	305 mm	270 mm	376–476 mm
<b>Special feature</b>	Simple adjustment to smaller material inlets with adapter plates	Improved sensitivity	Use in clean rooms according to ISO 14644-1	Easiest adaption to larger material inlets with machine adapter

## Options

<b>Monitoring Package</b>	Measurement of color fluctuations, temperature and humidity
<b>Interfaces options</b>	Ethernet, WLAN, USB, Profibus, Profi.NET

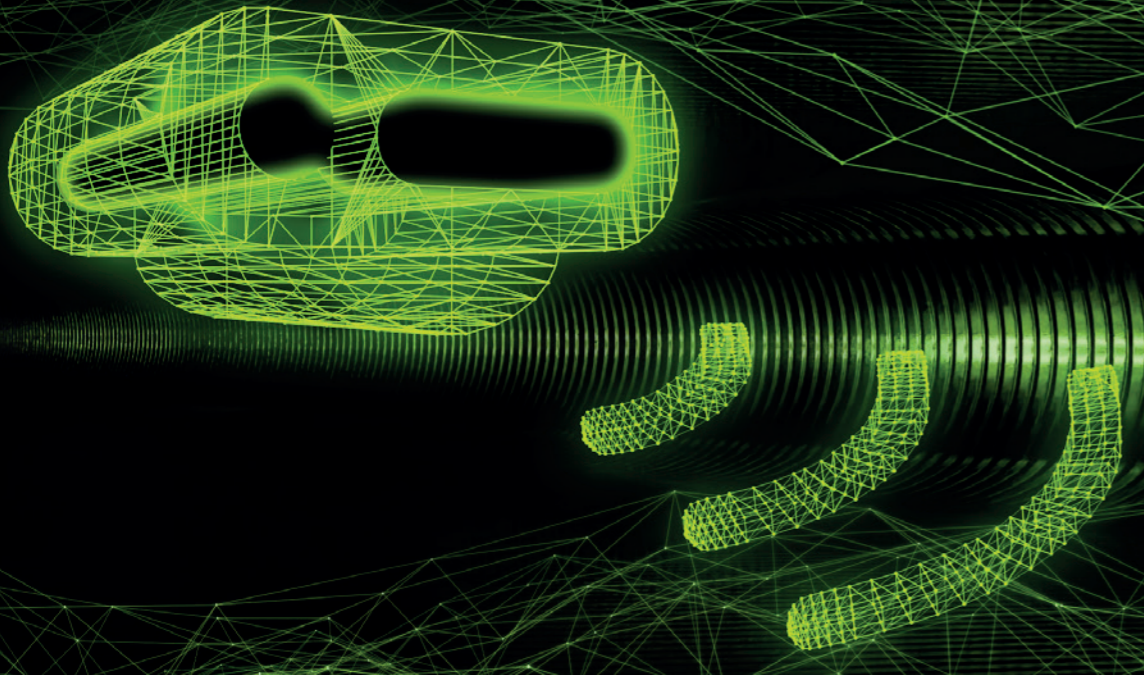

# MONITORING PACKAGE

MONITORING.PACKAGE

## Highly efficient systems with powerful sensors



### Challenge:

- Fluctuating product quality
- Inconsistent input material
- Little to no overview of process parameters

This situation leads to anomalies in the processing of plastics, which not only jeopardize the processing machines and equipment but also reduce production efficiency. If the anomalies are not detected, there is a significant risk of quality losses for one's own customers.

### Typical application areas:

- injection molding
- extrusion

### The solution:

Three powerful sensors for measuring color, humidity, and temperature.

**C** Colour

Detection of color differences in the conveyor line

#### Benefits/Customer advantages:

- Quick integration into the processing line
- Less plastic waste
- Consistently high product quality

**H** Humidity

Detection of humidity fluctuations in the conveyor line

#### Benefits/Customer advantages:

- Constant melting point of the conveyed material
- Process optimization
- Consistently high product quality

**T** Temperature

Detection of temperature fluctuations in the conveyor line

#### Benefits/Customer advantages:

- Low energy consumption for the melting process
- Environmentally friendly
- Higher profit for your company

### Benefits for the customer

#### Anomaly detection in the plastic processing process ensures:

- Higher machine protection and less downtime
- Consistent product quality
- Evaluation and display via the corresponding dashboard

# For pneumatic conveying









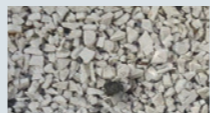

Metallic contaminants in plastic granulates or regrind lead to clogged nozzles, filters, damaged machines, or contaminated end products.  
The solution: Sesotec metal detectors for suction or pressure conveying



GF  
from page 44

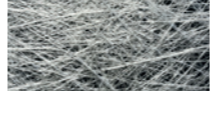
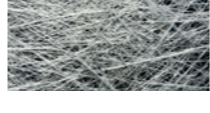
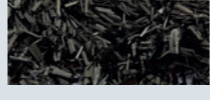

GF  
from page 44

		GF (vacuum conveying) page 44	GF (pressure conveying) page 44
	<b>granulate</b> (<math>\lt; \varnothing 8 \text{ mm}</math>) well flowable, unless the material is resinous	✓	✓
	<b>regrind</b> (<math>\lt; \varnothing 8 \text{ mm}</math>) moderate flowability, as long as only a small proportion of powder is contained	✓	✓
	<b>flakes</b> (<math>\lt; \varnothing 14 \text{ mm}</math>, thinner than 1,5 mm) flexible, poorly flowable, bridging	✓	✗
	<b>PET-flakes</b> (<math>\lt; \varnothing 14 \text{ mm}</math>, thinner than 1,5 mm) flexible, poorly flowable, bridging, abrasive	✓	✗
	<b>chips</b> (><math>\varnothing 10 \text{ mm}</math>) poorly flowable due to large size	✗	✗
	<b>shredded material</b> (><math>\varnothing 10 \text{ mm}</math>) poorly flowable due to size and thickness	✗	✗
	<b>powder</b> (<math>\lt; \varnothing 1 \text{ mm}</math>) poorly flowable, powder accumulates in the corners and edges of the separation unit	✓	✓
	<b>powder</b> (moisture absorbing, <math>\lt; \varnothing 1 \text{ mm}</math>) clumping occurs upon contact with moisture	✓	✓
	<b>foil scraps</b> poorly flowable, have the property of accumulating over the ejection flap	✗	✗
	<b>fibers</b> (shorter than 8 mm) moderate flowability, can accumulate in the metal separator	✓	✓
	<b>fibers</b> (longer than 8 mm) moderate flowability, can become over the ejection flap	✗	✗
	<b>glass fibers</b> (shorter than 8 mm, share <math>\lt; 20\%</math>) moderately flowable, abrasive	✓	✓
	<b>glass fibers</b> (shorter than 8 mm, share <math>\geq 20\%</math>) moderately flowable, abrasive	✓	✓
	<b>carbon fibers</b> (shorter than 8 mm) moderately flowable conductive = product effect!	✓	✓

FOR PNEUMATIC CONVEYING

# GF

For the inspection of granulate, regrind, or regranulate in vacuum or pressure conveying lines

up to <b>80</b> °C	up to <b>20</b> m/s	up to <b>8</b> mm
Product temp.	Speed	Particle size

## Easy integration

The modular design and suitable pipe connections enable easy integration into existing pipelines – for vacuum and pressure conveying in horizontal and vertical configurations

## Reliability

Safe ejection of contaminants starting from 0.7 mm V2A without interrupting the conveying flow – even at high conveying speeds

## Machine protection and process optimization

By combining the GF with the special Sesotec flyball test body, the actual product speed in the conveying line can be derived. An important process parameter as an add-on to Sesotec hardware for machine protection



vertical



For granulates and regranulates as well as regrind

**Free consultation**

<https://www.sesotec.com/contact>



## Technical data GF

Type designation	GF-40-PP	GF-50-PP	GF-60-PP	GF-70-PP	GF-90-PP	GF-100-PP	GF-120-PP	GF-150-PP
Inlet connection diameter (top)	40 × 1.5	50 × 1.5	60 × 2	70 × 2	104 × 2	50 × 2	129 × 2	154 × 2
Good outlet connection diameter (bottom)	40 × 2	50 × 2	60 × 2	70 × 2	90 × 2	100 × 2	120 × 2	150 × 2
Connection diameter (optional)				76 × 2	88.9 × 2			
Conveying direction	Horizontal/vertical							

Scope of delivery	Compact unit with integrated metal detection coil, separation unit with collection container, and detached control unit PRIMUS+; inlet and good outlet with smooth pipe connection fittings and Jacob connection at the collection container
Particle shape	Granulate, regrind, flakes
Particle size max.	Ball Ø <8 mm
Flowability	Good, medium
Property	Dry, moist, non-abrasive, possibly existing product effect (inherent conductivity of the product) can be compensated
Material flow	Vacuum or pressure conveying (air conveying)

Conveying method: no pushing-type plug conveying, but constant air conveying.

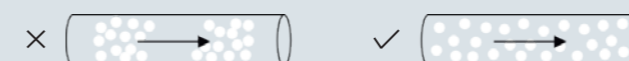

## Option

Stainless steel surfaces treated	For the use of difficult-to-handle materials.
----------------------------------	---

	Horizontal conveying	Vertical conveying
from left to right	✓	✗
from right to left	✓	✗
from bottom to top	✗	✓
from top to bottom	✗	✓

## Accessories

**Insight.360**  
Communication module for the digital integration of Sesotec devices into central company networks

## 2 Magnets

Our magnetic systems for free-fall applications can be quickly and easily integrated into all production lines for powdered and granular bulk materials or in material columns of granulates. Whether you are manufacturing plastics, pharmaceuticals, or plastic products – with the pipe magnets, you reliably protect consumers and machines from magnetic foreign objects. By securely separating ferromagnetic particles, they provide highly efficient protection against equipment downtime and costly repairs.



# Free-fall applications and material column

Standalone or in combination with a metal detector: Fine magnetic foreign bodies are separated from the particle flow without any power



EXTRACTOR SE  
from page 50

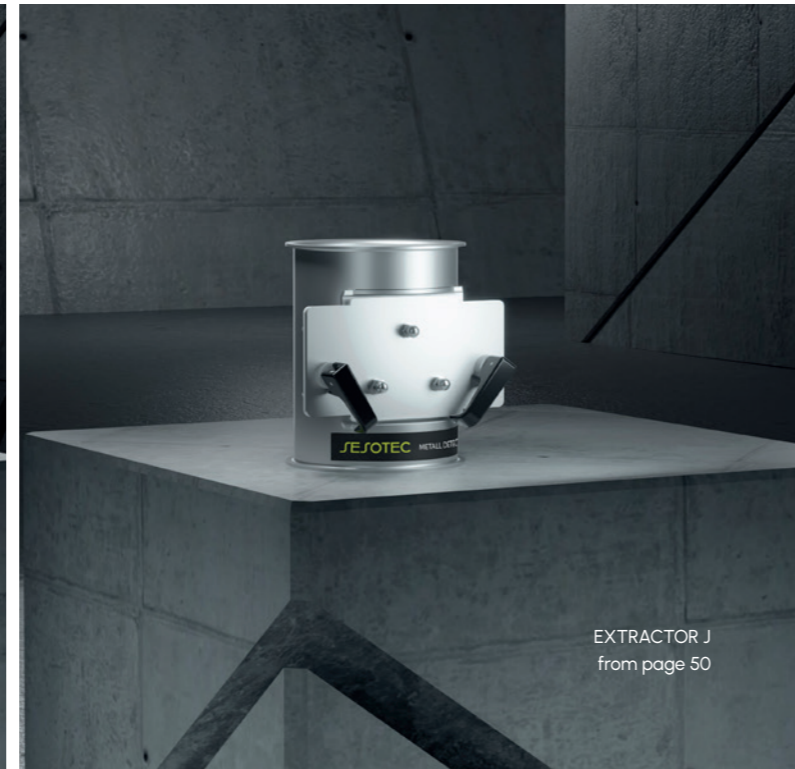







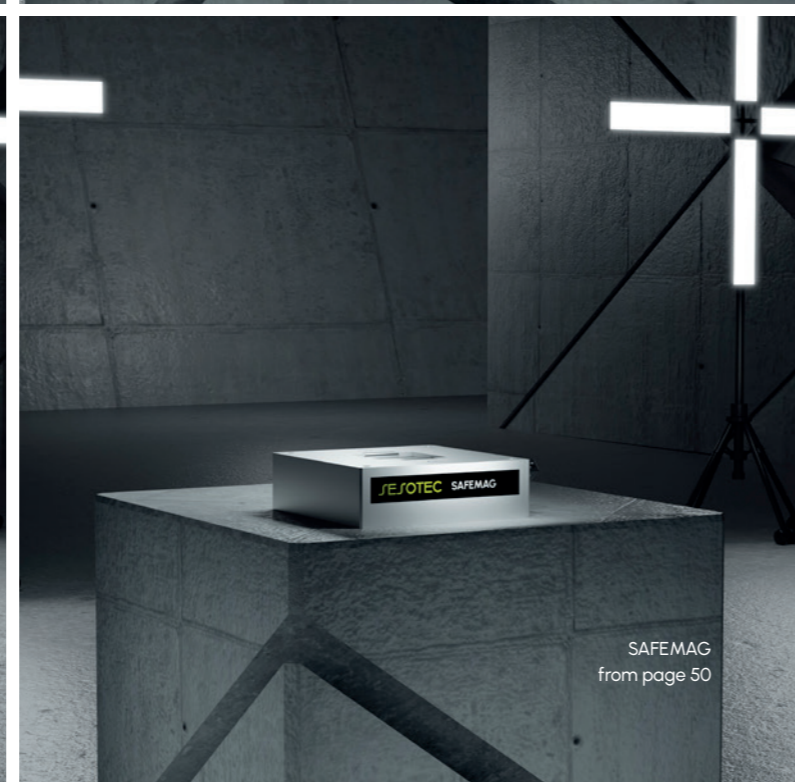

EXTRACTOR J  
from page 50



MAGBOX  
from page 50

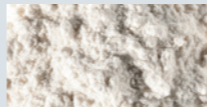

SAFEMAG  
from page 50

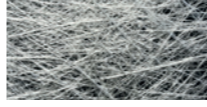
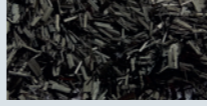
		EXTRACTOR SE	EXTRACTOR J	MAGBOX MXP	SAFEMAG
		page 50	page 50	page 50	page 50
	<b>granulate</b> (<math>\lt; \varnothing 8 \text{ mm}</math>) well flowable, unless the material is resinous	✓	✓	✓	✓
	<b>regrind</b> (<math>\lt; \varnothing 8 \text{ mm}</math>) moderate flowability, as long as only a small proportion of powder is contained	✓	✓	✓	✓
	<b>flakes</b> (<math>\lt; \varnothing 14 \text{ mm}</math>, thinner than 1,5 mm) flexible, poorly flowable, bridging	✗	✗	✓	✗
	<b>PET-flakes</b> (<math>\lt; \varnothing 14 \text{ mm}</math>, thinner than 1,5 mm) flexible, poorly flowable, bridging, abrasive	✗	✗	✓	✗
	<b>chips</b> (><math>\varnothing 10 \text{ mm}</math>) poorly flowable due to large size	✗	✗	✗	✗
	<b>shredded material</b> (><math>\varnothing 10 \text{ mm}</math>) poorly flowable due to size and thickness	✗	✗	✗	✗
	<b>powder</b> (<math>\lt; \varnothing 1 \text{ mm}</math>) poorly flowable, powder accumulates in the corners and edges of the separation unit	✓	✓	✓	✓
	<b>powder</b> (moisture absorbing, <math>\lt; \varnothing 1 \text{ mm}</math>) clumping occurs upon contact with moisture	✓	✓	✓	✓
	<b>foil scraps</b> poorly flowable, have the property of accumulating over the ejection flap	✗	✗	✗	✗
	<b>fibers</b> (shorter than 8 mm) moderate flowability, can accumulate in the metal separator	✓	✓	✓	✓
	<b>fibers</b> (longer than 8 mm) moderate flowability, can become over the ejection flap	✗	✗	✗	✗
	<b>glass fibers</b> (shorter than 8 mm, share <math>\lt; 20\%</math>) moderately flowable, abrasive	✗	✗	✗	✗
	<b>glass fibers</b> (shorter than 8 mm, share <math>\geq 20\%</math>) moderately flowable, abrasive	✗	✗	✗	✗
	<b>carbon fibers</b> (shorter than 8 mm) moderately flowable conductive = product effect!	✗	✗	✗	✗

# EXTRACTOR SE/J MAGBOX MXP / SAFEMAG

For the inspection of free-falling bulk materials or slowly moving material columns



For granulates and regranulates as well as regrind

**Free consultation**  
<https://www.sesotec.com/contact>



## Easiest installation

Sizes tailored to common pipe diameters ensure the easiest installation in existing conveying lines. This avoids costly modifications and allows for easy renewal

## Comprehensive care package

All magnetic separators can be easily combined with a metal separator. The interaction ensures contamination-free material and a secure process with the highest product quality. Magnetic dust and metallic foreign bodies are safely separated



## Various magnetic strengths

Depending on customer requirements, we offer various magnetic strengths

## The essentials at a glance

- Even dust is filtered out
- All common sizes available
- Easiest installation through adaptation options
- Use in free fall and in material columns
- Ease of use through removable magnetic grids





## Your benefits

- Quality assurance: Consistent product quality, protection against complaints, and traceability through logbook functionality
- Process safety: Reliable and precise separation prevents downtime due to tool damage
- Cost-effectiveness: High line availability due to short cleaning times and reduced manual effort

Magnets for use by plastic processors and manufacturers must meet specific requirements:

- Separation of the finest dust as well as smaller particles
- Robust construction
- Easy and quick installation

## Technical data

	 EXTRACTOR SE	 EXTRACTOR J	 MAGBOX MXP	 SAFEMAG
<b>Nominal widths</b>	40–150 mm	120–150 mm	100–400 mm 150/150–400/400 mm	40–60 mm
<b>Application</b>	Dry, well flowable, no long-fiber materials, Particle size <8 mm	Dry, well flowable, no long-fiber materials, Particle size <8 mm	Dry, well flowable, no long-fiber materials, Particle size <10 mm	Dry, well flowable, no long-fiber materials, Particle size <8 mm
<b>ATEX suitability</b>	Yes	Yes	Yes	Yes
<b>Magnet material</b>	High-energy neodymium magnet	High-energy neodymium magnet	High-energy neodymium magnet	High-energy neodymium magnet
<b>Number of available sizes</b>	9	2	13	3
<b>Installation height</b>	165 mm	165 mm	274–334 mm 205–220 mm	60 mm
<b>Ambient temperature</b>	-10 °C up to +50 °C	-10 °C up to +50 °C	-20 °C up to +60 °C	-20 °C up to +60 °C
<b>Product temperature</b>	Max. 80 °C	Max. 80 °C	Max. 80 °C	Max. 80 °C
<b>Free fall over device top edge</b>	Max. 500 mm	Max. 500 mm	Max. 1000 mm	Max. 200 mm

## Options

<b>Laser-cut flat flanges according to DIN 2632</b>	Easy adaptation to existing pipelines
<b>Leak testing</b>	For use in ATEX dust zones

### 3 Material Management Systems

Reintroducing recyclates and regrind into the plastic cycle is the ultimate goal of sustainable plastic production and processing. Fluctuating quality levels of the input material present significant challenges to every production process. By analyzing as quality control at the goods exit or to verify the input material, the predictability of production processes and thus efficiency is secured. Through mobile processing as a preceding automated work step, previously inadequate recycle meets quality requirements – and becomes an economic advantage.

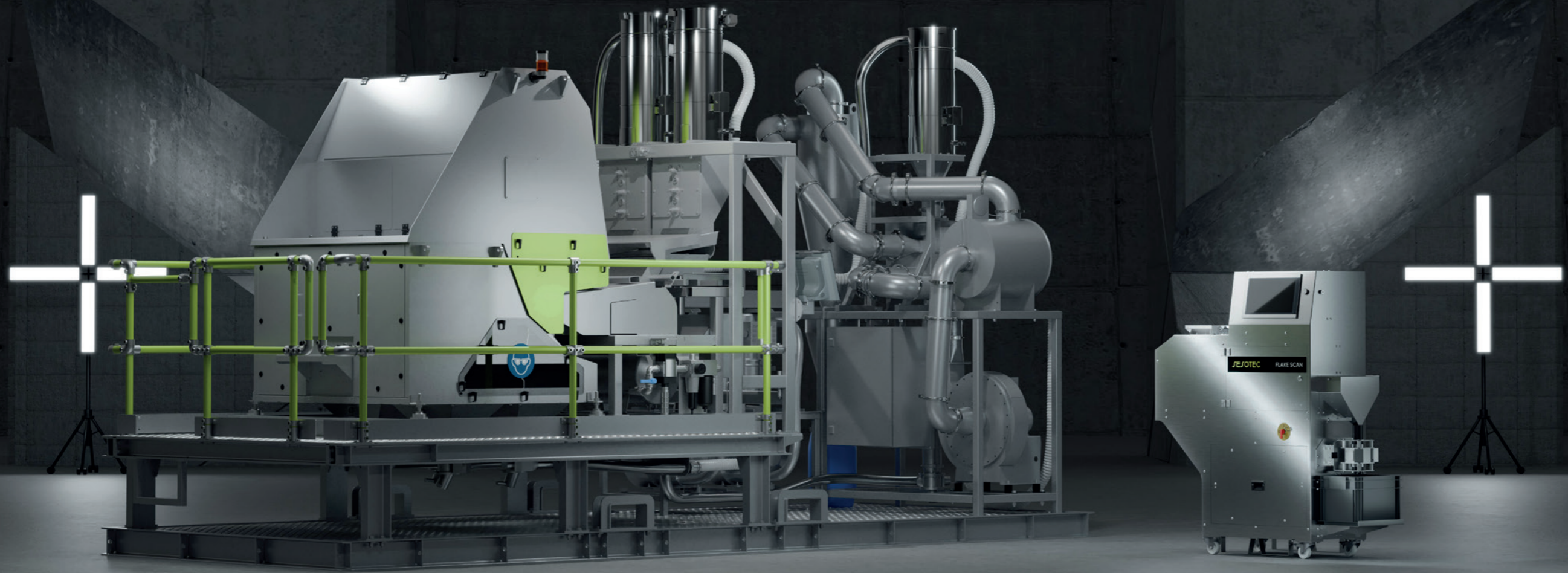

# Material analysis and processing







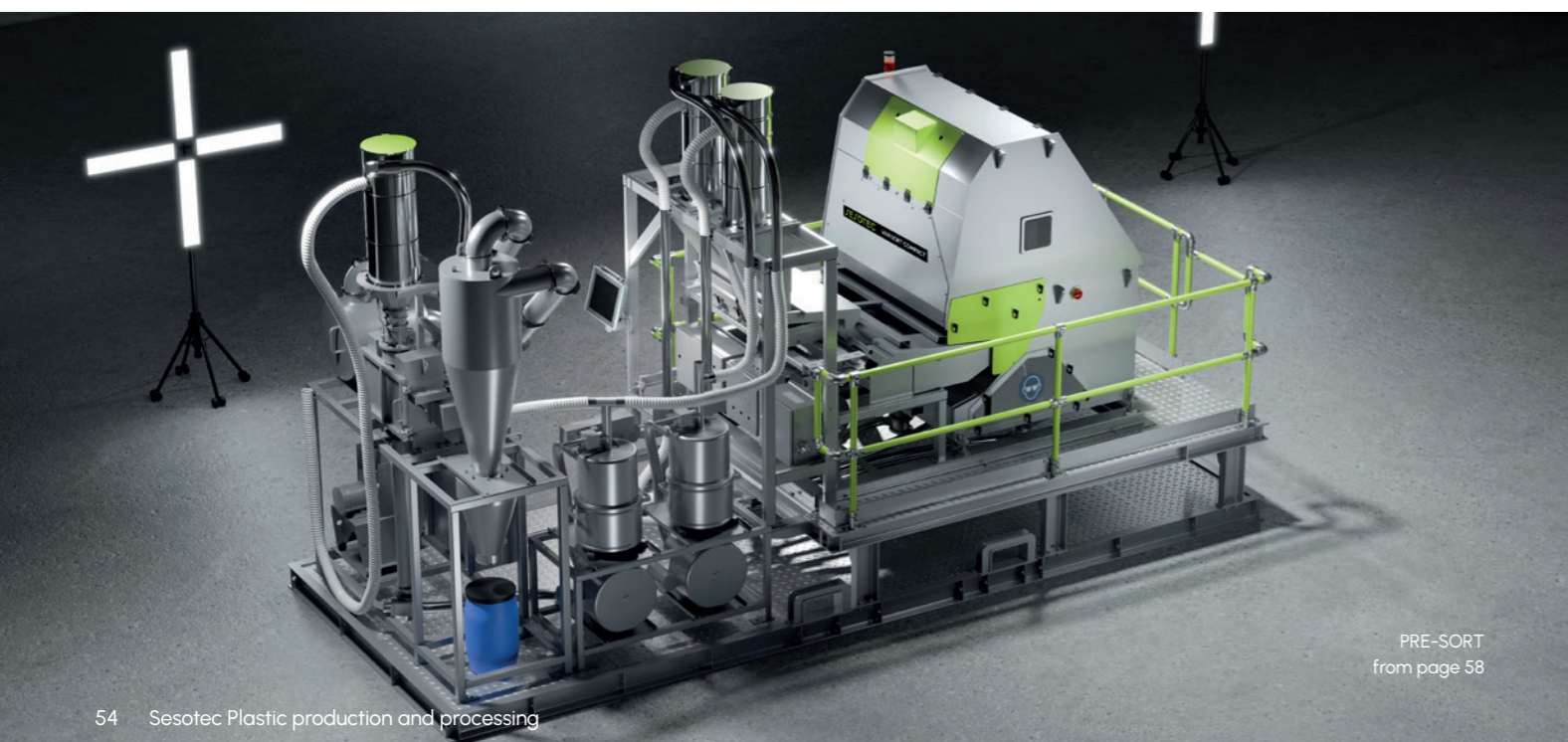

Recognize in seconds, using the overview on the right, which of your products are suitable for the Sesotec material management systems

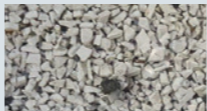

FLAKE SCAN  
from page 56

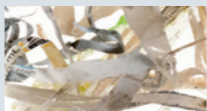
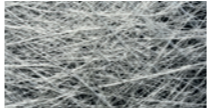
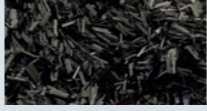

PRE-SORT  
from page 58

		FLAKE SCAN	PRE-SORT
		page 56	page 58
	<b>granulate</b> (<math>\lt; \varnothing 8 \text{ mm}</math>) well flowable, unless the material is resinous	✗	✓
	<b>regrind</b> (<math>\lt; \varnothing 8 \text{ mm}</math>) moderate flowability, as long as only a small proportion of powder is contained	✓	✓
	<b>flakes</b> (<math>\lt; \varnothing 14 \text{ mm}</math>, thinner than 1,5 mm) flexible, poorly flowable, bridging	✓	✗
	<b>PET-flakes</b> (<math>\lt; \varnothing 14 \text{ mm}</math>, thinner than 1,5 mm) flexible, poorly flowable, bridging, abrasive	✓	✗
	<b>chips</b> (><math>\varnothing 10 \text{ mm}</math>) poorly flowable due to large size	✓	✗
	<b>shredded material</b> (><math>\varnothing 10 \text{ mm}</math>) poorly flowable due to size and thickness	✗	✗
	<b>powder</b> (<math>\lt; \varnothing 1 \text{ mm}</math>) poorly flowable, powder accumulates in the corners and edges of the separation unit	✗	✗
	<b>powder</b> (moisture absorbing, <math>\lt; \varnothing 1 \text{ mm}</math>) clumping occurs upon contact with moisture	✗	✗
	<b>foil scraps</b> poorly flowable, have the property of accumulating over the ejection flap	✗	✗
	<b>fibers</b> (shorter than 8 mm) moderate flowability, can accumulate in the metal separator	✗	✗
	<b>fibers</b> (longer than 8 mm) moderate flowability, can become over the ejection flap	✗	✗
	<b>glass fibers</b> (shorter than 8 mm, share <math>\lt; 20\%</math>) moderately flowable, abrasive	✗	✗
	<b>glass fibers</b> (shorter than 8 mm, share <math>\geq 20\%</math>) moderately flowable, abrasive	✗	✗
	<b>carbon fibers</b> (shorter than 8 mm) moderately flowable conductive = product effect!	✗	✗

# FLAKE SCAN

Quality analysis of plastic flakes and regrind: instantaneously and without destroying the product

## C

Color sensor

## M

Metal sensor

## N

NIR sensor

## Efficient

Minute-by-minute sample analysis of plastic material by plastic types, colors and metal foreign bodies, as well as rapid evaluation of the composition of plastic batches

## Precise

Highly precise, automatic and reproducible analysis of material samples with the aid of up to three integrated sensors:

- C Color sensor
- M Metalsensor
- N Nearinfrared sensor (NIR)

## Profitable

With our FLAKE SCAN you can save time and money. The effort for a manual, visual and thermal examination is significantly reduced. In addition, a quick and reliable decision can be made on the usability of plastic flakes and regrinds - for a profitable use of plastic recycle

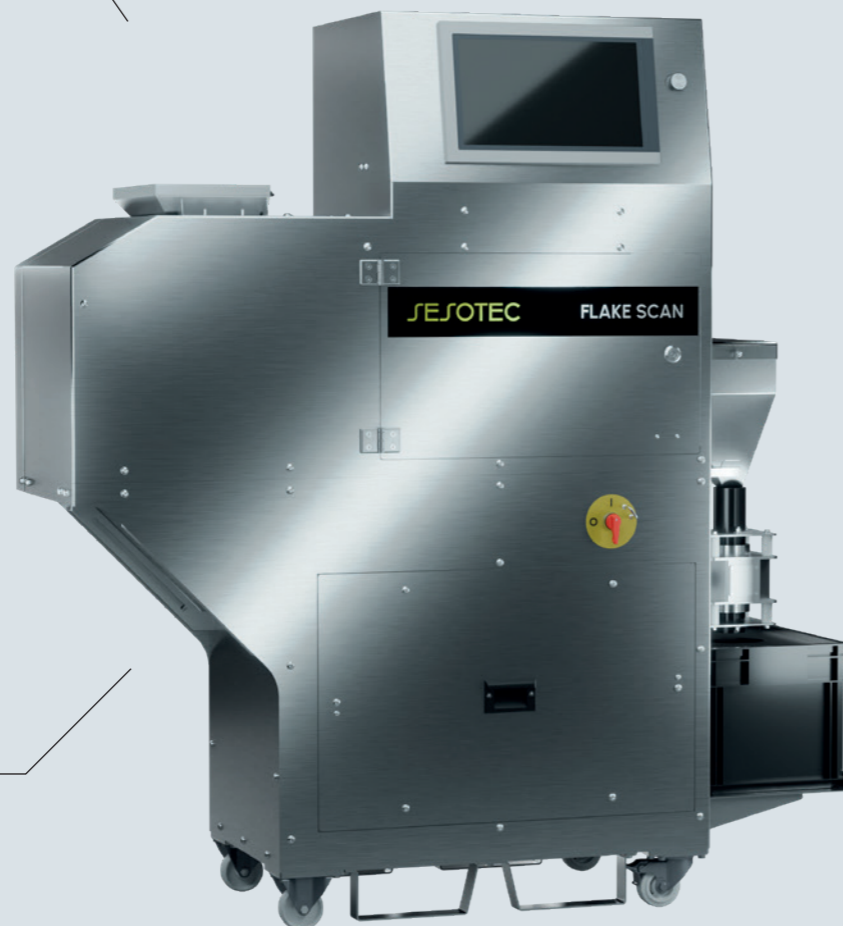

Quality analysis of plastic flakes and regrinds

**Free consultation**  
<https://www.sesotec.com/contact>



Companies that produce new granulate from recycle use the FLAKE SCAN material analysis system for incoming goods inspection. In recycling, the device is used by quality laboratories for outgoing goods inspection. In both areas, manual analyses have been conducted so far, which are time-consuming and whose results are not reproducible. In contrast, with FLAKE SCAN, reports on the composition of plastic types and on the proportion of off-color components can be generated within minutes, consistently high in quality and with reproducible results.

## SIMPLIFY YOUR LIFE – With the new features of the FLAKE SCAN

- Label Printer
- Barcode Scanner
- Flake Size Analysis

### Technical data FLAKE SCAN

Throughput up to (kg/h)*	20
Suitable grain size	2–20 mm
Power (max. KVA)	0.24
Temperature range	+5 °C up to +40 °C
Weight	291 kg
Electrical connection	Power connection cable 3 × 1.5 mm <sup>2</sup>
Electric fuse	10A
Protection class	IP54
Rated current (max. A)	1
Conveying pressure	Pressureless (free fall)
Flowability	Medium to good

\*The actual values that can be achieved may deviate from those specified and depend on the properties of the material as well as the external influences and conditions at the site.

discover  
more now



# PRE-SORT

The compact high-end system for regrind sorting

<b>CMN</b>	<b>1000</b>	<b>5-12</b>
Sensors	kg/h	mm
	Throughput	Grain size

## Mobility

Due to its design in the form of a self-contained sorting platform, the PRE-SORT can be transported from one location to another and can thus be used flexibly and at different locations

## Process variability

The PRE-SORT offers maximum process flexibility through any combination of sensors and a choice of different sorting sequences. Thanks to two tracks for automated double sorting, the sorting platform also ensures first-class material quality.

## Sensor flexibility

Intelligent sensors for color, polymer and metal sorting are combined in this device. Depending on the sensor combination selected, sorting can thus be performed according to colors, types of plastic and metals, or only according to individual factors

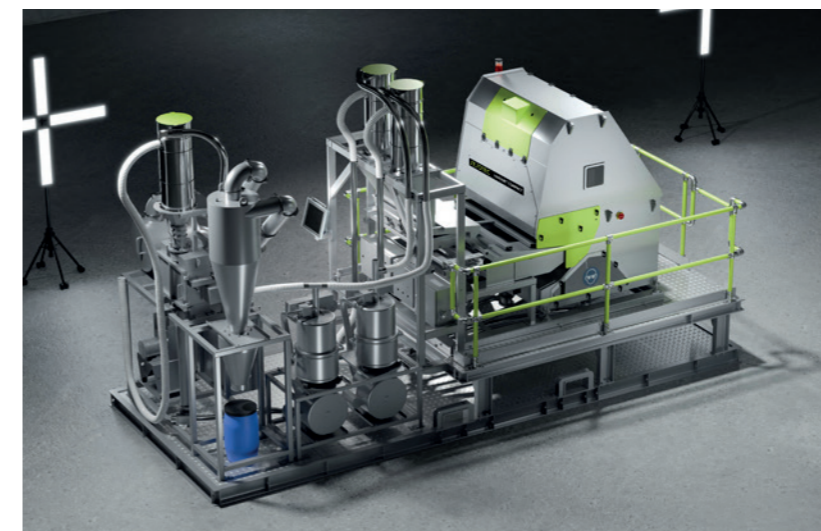
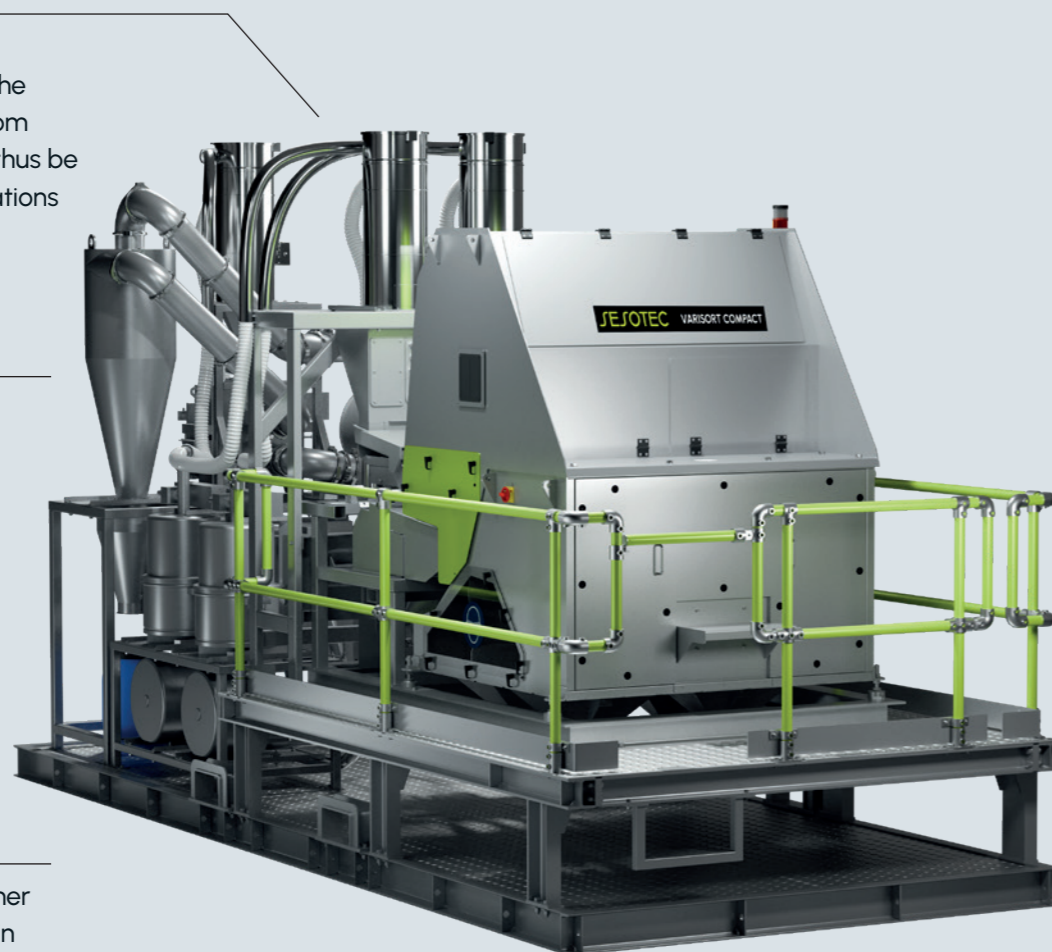

Application in plastic processing: Sorting of regrind

Free consultation

<https://www.sesotec.com/contact>



## Technical data

## PRE-SORT VCM

Working width [mm]	1024 (divided into two tracks)
Throughput up to [max. kg/h]	1000
Power [max. KVA]	14
Protection class	IP54
Dimensions	5900 x 2350 x 3270 mm (L x B x H)
Suitable products	Plastic, regrind
Suitable grain sizes [mm]	5-12
Temperature range	+5 °C to +40 °C
Compressed air consumption	0.5-3 m³/min

## Available options

<b>Bigbag Single Emptying Station</b>	Stable steel construction with lifting frame for big bags with a maximum of 2000 kg
<b>Bigbag Double Emptying Station</b>	Stable steel construction with lifting frame for big bags with a maximum of 2000 kg with automatic switching function for continuous operation
<b>Bigbag Filling Station</b>	Stable steel construction including a rotary flap and fill level sensor for two big bags and continuous operation
<b>Material Conveying Device</b>	Conveying device for use at the filling station

Not only plastic producers are struggling with rising prices for raw materials, supply chain bottlenecks, or damages to production facilities, leading to associated downtime. The same applies to plastic processors. So how does one achieve a stable production process, reliable supply chains, processable quality, and satisfactory utilization without relying on new materials? Several points can be mentioned here:

- 1 Sorting of different types of plastics in-house
- 2 Ejection of foreign bodies of different types
- 3 Direct connection to downstream processes
- 4 Optimal independence from suppliers
- 5 Marketing ambassadors as a demonstrated part of the circular economy

discover more now



# Experience and expertise for every application case

For over 50 years, Sesotec has stood for reliable solutions in detection and sorting technology and has established itself as a trusted partner for plastic manufacturers and processors worldwide. Our extensive expertise enables us to understand the complex requirements of the industry and develop customized systems that offer the highest precision and efficiency. Through continuous research and technological innovations, we guarantee our customers future-proof solutions that adapt flexibly to the changing conditions of the raw material market and the challenges of the circular economy.

Our deep understanding of production processes and quality requirements helps our customers minimize waste, maximize production security, and remain sustainably profitable. Trust in Sesotec – a company that has successfully balanced technological advancement and economic sustainability for five decades, always keeping the success of its customers in focus.

# 50 years of competence, quality, and innovation

Sesotec systems are characterized by the highest precision and reliability, ensuring consistently high quality in the production processes of the plastic manufacturing and processing industry. Highly precise, reliable, and durable components that prove themselves in the harsh industrial environment, combined with state-of-the-art sensors and intelligent software solutions, enable seamless process control and efficient resource utilization. Waste is reduced, profitability is increased, and the sustainability of the production process is enhanced. Innovation is at the core of our corporate philosophy. We continuously invest in research and development to further improve our products and meet the increasing demands of the circular economy. Our solutions are designed to respond flexibly to changing material flows and market conditions.

This is how we support you in making your processes even more efficient, sustainable, and futureproof – for a profitable production in a dynamic industry.



Practical example: Input materials like this make it difficult for plastic manufacturers and processors to ensure consistent production environments for uniform material quality.

# The perfect mix of hardware, software and service

More than just a manufacturer of high-tech inspection and sorting systems: Sesotec customers get comprehensive service that extends from product tests and equipment loans to commissioning, training and measures for extending the service lives of their devices.

For us, partnership means that we support you in every phase of the production and production lifecycle. You get everything from a single source. Competent. Flexible. Based on our more than 40 years of experience in service and maintenance and thousands of customer-specific projects. Increase machine availability. Minimise downtimes. Optimise production processes.

## Your Benefits at a glance

- Long-term maximum product quality
- Maximum service life and efficiency of your Sesotec machines and systems
- Minimum maintenance effort due to the comprehensive service and maintenance offering
- Secure auditing thanks to the maintenance and validation certificates issued by us
- Service reminders and proactive service planning by Sesotec
- Cost transparency over several years

# Your partner for sustainable production optimisation



## Right down the line – for life:

Regardless of the phase of its lifecycle that your Sesotec device is in: our experienced service technicians are there to assist you in word and deed. You can find out more about each stage on the following pages. Please don't hesitate to contact us if you require further information!

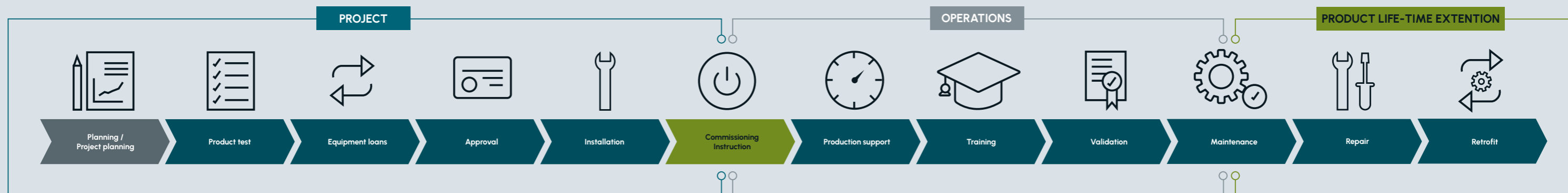

SHORTEST DELIVERY TIMES

# Fast, Faster, Fast Lane



An optimized alignment of production processes, among other things through lean methods, makes it possible to produce the proven metal separators of the PROTECTOR, RAPID VARIO-FS, and GF series as „Fast Lane“ products ready for shipment within just five working days from order placement. The global shipping capability of these devices guarantees availability at an international level. With this performance, we emphasize our market leadership and reliability in the plastic industry.



Want to learn more about our technology for manufacturing?

Get in touch with us directly! We look forward to advising you.  
You can reach us at:

**+49 (0) 8554 308-0**    **[www.sesotec.com](http://www.sesotec.com)**

## Imprint

# SESOTEC

Sesotec GmbH  
Regener Strasse 130  
D-94513 Schönberg

Phone: +49 (0) 8554 / 308-0  
Mail: [info@sesotec.com](mailto:info@sesotec.com)  
Website: [www.sesotec.com](http://www.sesotec.com)

Managing Director:  
Joachim Schulz | CEO  
Niklas Burkart | CFO

Register Court: Local Court of Passau  
Commercial register no. HRB 3163  
VAT ID: DE 81 151 25 77

Concept, text, design:  
Sesotec GmbH

Picture credits/Copyright:  
All image rights reserved by  
the company Sesotec GmbH.