



Food Safety

METAL DETECTION & METAL SEPARATION

Free-fall applications

Product family overview

Metal separation in free-fall conveying lines

Our free-fall metal separators have been specially developed for use in free-fall conveying lines with hygienic requirements. They reliably detect and separate magnetic and non-magnetic metal contaminants from granular, fibrous and powdered bulk materials – even if they are enclosed in the product. Due to their low installation height, the metal separators can be easily integrated into existing piping systems. In addition, the modular design allows individual adjustment of the free-fall height and the position of the outlet for impurities.

Innovative Technologie

The P-SCAN RG metal detector, the heart of our free-fall machines, guarantees reliable detection of magnetic and non-magnetic metal contaminants through single or dual frequency technology. With over 30 coil variants, it can be easily adapted to all customer-specific requirements.

UL/CSA certified

All our metal detectors and metal separators are UL/CSA certified.



Made in Germany

All our metal detectors and metal separators are developed and produced in Germany.



Individual kit

Depending on the free-fall application, different metal separators (RAPID 4000, RAPID 5000, RAPID 6000 and RAPID 8000) are available – based on the detection unit with integrated metal detector P-SCAN RG.

- A** P-SCAN RG
- B** Detection Unit RG
- C** RAPID 4000
- D** RAPID 5000
- E** RAPID 6000
- F** RAPID 8000



A



B



C



D



E



F

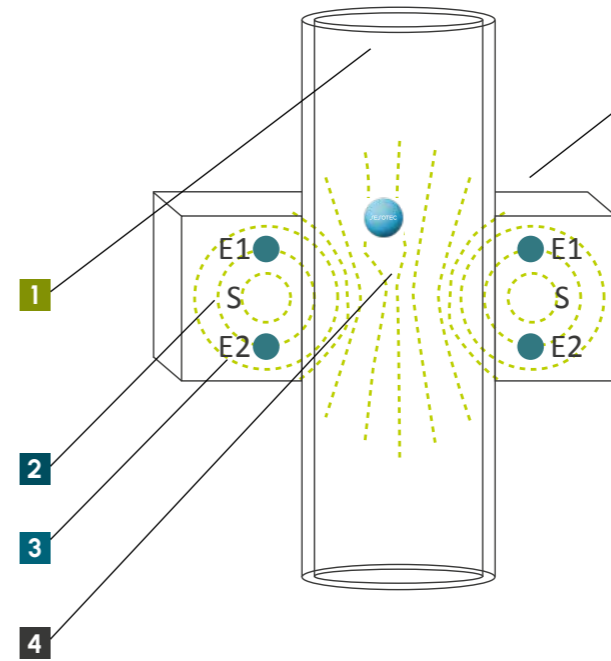

P-SCAN RG

- 1** Inside the sensing tube, an electromagnetic field passes through the material being conveyed.
- 2** The electromagnetic field emitted by the transmitter coil S induces two equal voltages ...
- 3** ... in the receiver coils E1 and E2.
- 4** A metal particle shifts the field lines of the transmitter, which changes the voltages induced in the receiver windings. This voltage change is evaluated by the control unit and converted into a switching pulse.



GENIUS ONE Control Unit

- New user interface with touch display for easy operation and various operation languages
- Permanent self-monitoring of all important system functions
- Faster teach-in, fewer operating errors and short operating times
- Cost and time savings through effective operating and service functions
- IOT-ready: USB port and integrated Ethernet interface for easy data transfer available
- Communication modul COMGateway.Embedded for digital integration into central company networks via an Ethernet or WLAN interface
- Compatible with Sesotec Insight.360
- Type tested up to ATEX Zone 21

Metal detection holistically thought through.

What applies to the food industry in particular also applies to all other manufacturing sectors: Product quality is the top priority. The delivery of defective or low-quality goods can have fatal consequences. We help you to safeguard yourself – with the help of innovative and highly precise metal detection. Our metal detectors quickly and reliably detect the smallest metal contaminants in the product stream – regardless of their size, shape or position. They can be used at incoming goods for the inspection of bulk materials or pre-products as well as in the middle of the production line and at the end for outgoing goods inspection.

Typical fields of application in food and feed production

We support food and feed producers in ensuring both the best possible quality and compliance with all current standards. Our free-fall systems are perfectly suited for the following applications:

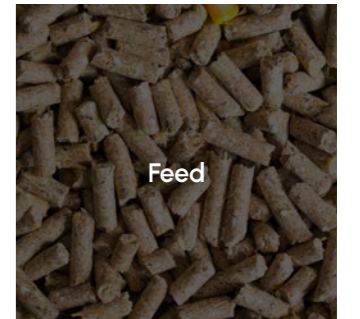
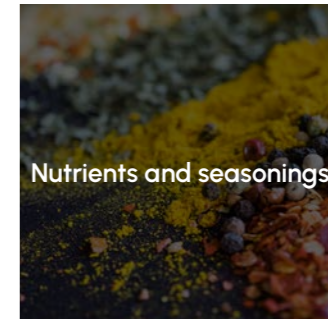
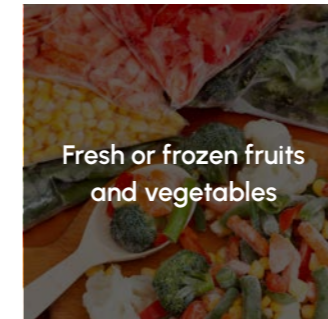
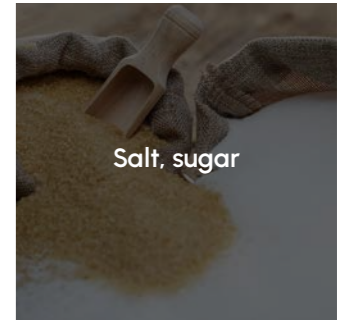
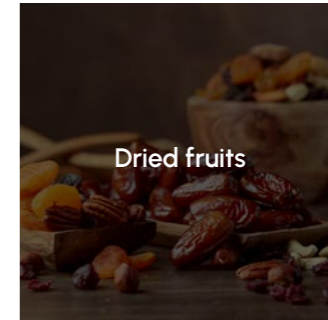
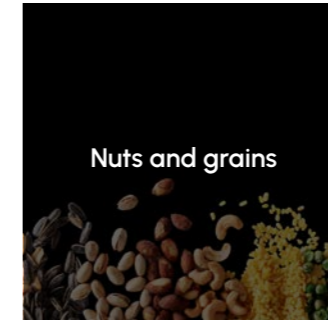
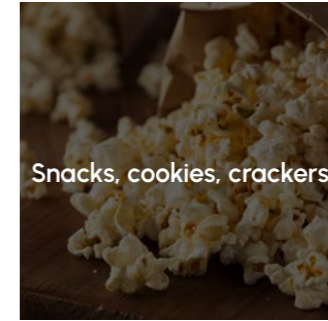

Metal separator RAPID

Thanks to innovative single- or dual-frequency technology, no metal particle remains undetected even during material delivery. Depending on the material characteristics, different reject mechanisms are available for fully automatic rejection.

MAGBOX Food

Our inline magnets, specially developed for free-fall applications, reliably separate fine and ultra-fine ferrous metal contaminants as well as lightly magnetized stainless steel particles from the bulk material falling through them.

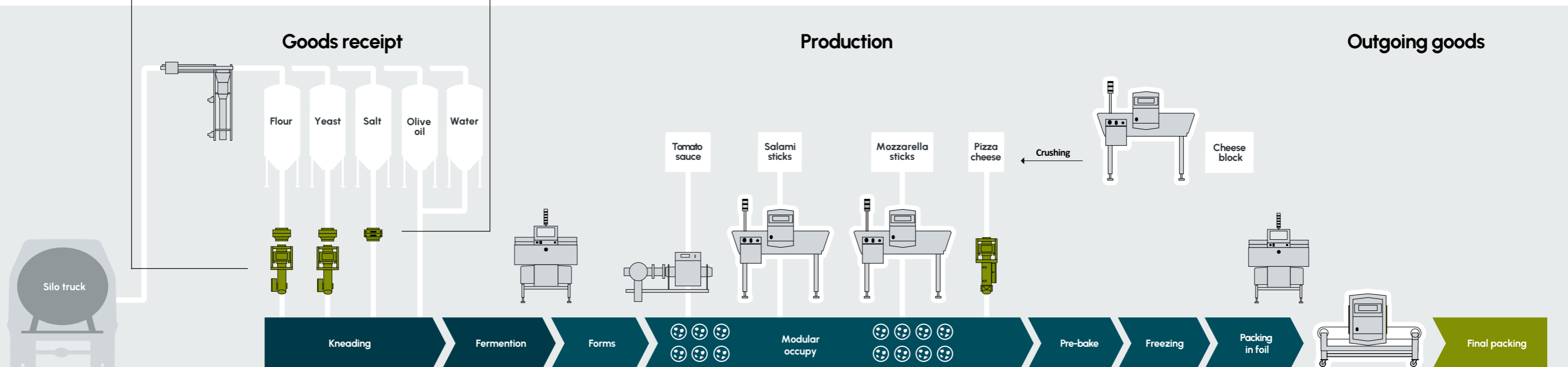

Your priorities. Our answers.

The development of our metal separation systems revolved around one thing in particular: Your priorities. With the help of extensive analyses and background discussions, we identified the most important requirements for foreign object detection – and intensively researched solutions. Successfully. Our Sesotec 6-priorities concept provides viable answers to all your challenges.



P1 Conformity & Accuracy

Highest detection sensitivities even with strong product effects due to single or dual frequency technology, automatic product compensation and digital signal processing.

P2 Safety for people & products

Safe rejection of metals through features such as compressed air monitoring and monitoring of the separation unit provides the consumer with products free of contamination.

P3 Simple operating concept

Using a 5" color touch display with intuitive menu navigation, you can configure our systems easily and quickly for various applications. Operating errors are virtually impossible.

P4 Hygienic design concept

Robust and hygienic housings allow easy cleaning and maintenance.

P5 Efficiency in all areas

Intelligent sensitivity adjustment and high interference immunity prevent false triggering and increase profitability.

P6 Reliable & fast service

With warranty services, a combined on-site and remote service, and targeted training, you have optimal support for smooth operation.



Conformity & Accuracy

Our metal separators support and facilitate compliance with the necessary food safety requirements

Compliant with international safety standards

With our metal separators you are on the safe side as far as international standards are concerned.

- Audit Check: Guides through the audit routine and logs all steps (quality monitoring)
- IFS compliant (exceeds the detection accuracy requirements of the international food safety standard)
- UL/CSA certified

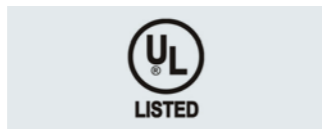

Manual testing device

For daily verification, a test sample is placed in the conveying line immediately upstream of the metal separator.

It passes through the search coil inside the sensing tube and is then rejected or, in the case of faulty detection or faulty separation, separated from the bulk material by means of a collecting grid.

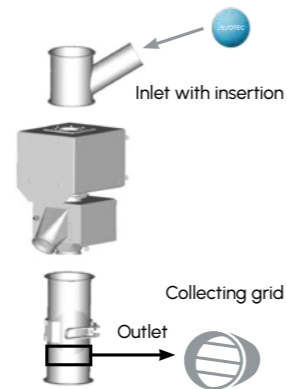

COMGateway.Embedded

The communication module enables the digital integration of Sesotec devices into central company networks via Ethernet or WLAN.

- It enables intermachine communication and data exchange with ERP or PPS systems
- Various protocols are available for communication: OPC-UA, SSTProt, MQTT and Rest API
- The hardware interface is mounted directly in the electronics housing



Safety for people & products

The system is safe for brand, product, personnel and data

Optimized for the best safety

Automatic compressed air monitoring

A built-in pressure switch enables monitoring of the separation unit's compressed air supply. If compressed air is missing or not connected, the pressure switch opens the contact and the connected control unit displays an error message on.

Function monitoring of the separating unit

Inductive sensors monitor both the flap positions (idle state and rejection position) as well as the speed of the flap movement in case of a metal detection, as well as all test and manual switching operations. With this function monitoring, up to 12 different error states can be distinguished and displayed.

High data security guaranteed

- The definition of different user groups with specific rights facilitates access protection (e.g. Service, Admin & Operator).
- With the user administration, individual access authorizations can be assigned to an operator.
- The "Login2Go" function saves the data on a USB stick. This saves logging in with password entry.

Type-tested ATEX version



The ATEX regulations from EU Directive 2014/34/EU require that within the EU, all equipment used in potentially explosive atmospheres must comply with the recast ATEX Directive. Our RG Detection Unit and the RAPID 5000 are available in type-tested ATEX versions up to Zone 20 (indoors) and Zone 21 (outdoors) for use in areas where there is a risk of dust explosion.





Simple operating concept

Simple operation provides a good user experience, facilitates handling and minimizes the risk of errors

Clever support through our software

- Multi-product memory: Device settings for up to 300 different products can be stored. Product changeover is quick and easy, including the possibility of batch tracing by querying a batch number.
- Auto learn function with product compensation: automates the product-specific device settings and prevents false triggering due to intrinsic product effects (e.g. salts, humidity, etc.) by automatically determining the best device setting – while at the same time ensuring high interference immunity.

Easy operation thanks to Insight.360

Optimal traceability through seamless logbook and optional image archiving

Insight.WEB is a software for the Operation and monitoring of all metal detectors and metal separators from a central control station.

INTERLINK+ is a communication module for digital integration of Sesotec devices into central company networks. It enables a targeted increase in productivity through central process analysis, monitoring and control, as envisaged in Industrie 4.0.



Access to important system functions

The clear display on the start screen contains all important system functions at a glance.



Hygienic design concept

Depending on the hygienic requirements, the systems offer a corresponding design for simple, effective cleaning and maintenance

Hygienic design

The complete stainless steel and plastic construction makes our metal separation systems ideal for the food industry.

- Hygienic design of the four available separation units
- Use of materials that can be repeatedly cleaned intensively without abrasion
- Up to protection class IP65 as standard
- Complete structure made of stainless steel and plastics in contact with the product with suitability for the food sector (according to EG1935/2004)



The RAPID 6000 has an enlarged cleaning opening with removable funnel

Easy Clean swiveling device (RAPID 4000/5000)



Efficiency in all areas

Increase output, save working time and avoid food waste

Permanent system monitoring

Sensitivity adjustment and high interference immunity prevent false triggering and increase profitability. Constant system monitoring ensures early detection of malfunctions, such as temperature fluctuations, voltages on the board or receiver voltage.

Easy integration into existing pipelines

Due to their low installation height, our free-fall applications can be easily integrated into existing piping systems. In addition, the modular design allows individual adjustment of the free-fall height (standard 500 mm, optional up to 1 m) and the position of the bad outlet.

Large pipe diameter

Larger pipe diameters of 300 and 350 mm are available for the RAPID 8000 for more throughput and added efficiency.

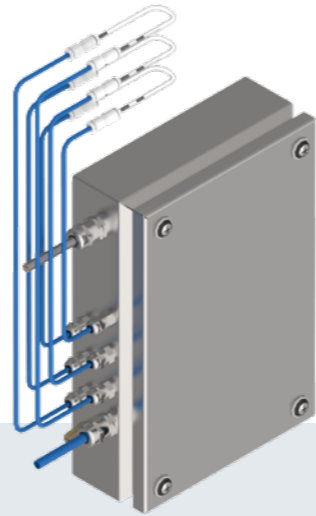

Automatic function test module

Additional safety is provided by the optional function test module, which enables ongoing function testing without additional effort.*

- Start of the function test manually or automatically (time interval can be set): A trigger signal is sent to the control unit
- Automatic function check: Pneumatic tube between coil and sensing tube, in which a test sample can be moved through the coil by compressed air
- Particularly suitable for devices that are difficult to access
- Time and cost savings due to elimination of manual function test

* Application-dependent due to nominal size and temperature



Reliable & fast service

Ensure and improve performance, provide fast help in case of unexpected failures, prevent problems

The Sesotec Service: Global. Competent. Responsive.

In addition to first-class equipment and systems, Sesotec also offers you first-class service for all aspects of foreign object detection. Our service includes a variety of alternatives that flexibly adapt to your individual application. Our service thus offers you long-term investment and planning security.

NEW

Service ticket generation directly in the Sesotec app



Telephone support

Many questions and incidents can be resolved over the phone. Our free telephone support is available daily from 6 am to 8 pm and on weekends from 8 am to 5 pm. Fast, simple, effective.



Remote Access

Frequently, malfunctions on machines can also be remedied via remote access. Sesotec service technicians have direct access to your machines via Ethernet connection and can perform error analyses, optimizations and parameter settings.



Remote support with augmented reality

In addition to telephone support and remote access, Sesotec also offers video-based support with augmented reality. This is done via the Team-Viewer Pilot app.



Sesotec spare and wear parts packages

With the preventive spare and wear parts package for our devices and systems, you have the supplies you need in the event of machine downtime and can quickly and easily replace mechanical components yourself.

365

days

Our service is available to you 365 days a year and guarantees fast response times and proximity thanks to service centers located worldwide.



P-SCAN RG and Detection Unit

Metal detection system for the analysis of bulk materials, fibers or liquid/pasty products in pipelines

from
0.3
mm

Detection*

600
kHz

Frequency

Single-
or Dual-
Frequency

Technology

Versatile installation options

The P-SCAN RG can be easily installed in vertical, inclined or horizontal conveyor lines. In addition, it requires very little space due to its compact design with an extremely reduced metal-free zone.



Over 30 coil variants

With over 30 different coil variants for all common nominal pipe diameters, the P-SCAN RG can be perfectly adapted to customer-specific requirements.



Detection Unit RG: P-SCAN RG plus Detection Unit RG

Audit check

The audit check guides you through the audit routine with the help of a process wizard and logs all steps. This continuous quality monitoring is of enormous importance, especially for food producers and processors, in order to ensure consistently high product quality.



For granular or powdery bulk materials in free-fall conveying lines

Free consultation

<https://www.sesotec.com/emea/en/contact>



Technical data

| | P-SCAN RG | Detection Unit RG |
|---------------------------|--|--|
| Nominal widths | 30–600 mm | 50–250 mm |
| Detection accuracy | from Ø 0.20 mm FE and 0.30 mm V2A | from Ø 0.30 mm FE and 0.50 mm V2A |
| Frequency bandwidth | up to 600 kHz | up to 600 kHz |
| IP protection class | IP65 | IP65 |
| Number of available sizes | 17 (vertical), 17 (horizontal) | 7 |
| Installation height | 160–620 mm | 482–738 mm |
| Ambient temperature | -10 °C to +50 °C | -10 °C to +50 °C |
| Product temperature | -10 °C to +80 °C | max. +80 °C |
| Throughput | | max. 69,000 l/h |
| Conveying speed | 0.1-5 m/s best sensitivity up to 25 m/s max. possible | 0.1-5 m/s best sensitivity up to 25 m/s max. possible |
| Delivery pressure | | Pressureless or up to 0.1 bar |

Options

| | |
|--|--|
| Interfaces options | Ethernet, WLAN, USB, Profibus, Profi.NET |
| Available protocols for integration into the company network | OPC-UA, MQTT, Sesotec SSTProt, Rest API (via COM.Gateway.Embedded and Insight.360) |



Accessories

Insight.360

offers a wide range of features to help you monitor the manufacturing process.

Test bodies

In various sizes and configurations

GENIUS ONE Control Unit

- New user interface with touch display for easiest operation
- Permanent self-monitoring of all important system functions
- Faster teach-in, fewer operating errors and short operating times
- Cost and time savings through effective operating and service functions

RAPID 4000

Standard model for the detection of bulk materials in free-fall conveying lines

Quick
Flap

Mechanics

up to
69,000
l/h

Throughput

up to
8
mm

Grain size

Auto-learn function

Auto-learn function or manual product compensation for optimal adaptation to the intrinsic conductivity of the product under investigation and consequently a lower false rejection rate.

Easy Clean swivel device

For particularly easy cleaning, the RAPID 4000 has an Easy Clean swiveling device for the separating unit. After the product flow has been stopped, the separation unit can be swung to the side – for easy access to the separation and detection unit. A built-in safety switch deactivates the compressed air supply in the meantime.

Quick Flap

- Reliable rejection of metallic contaminants from 0.3 mm
- Low loss of good material

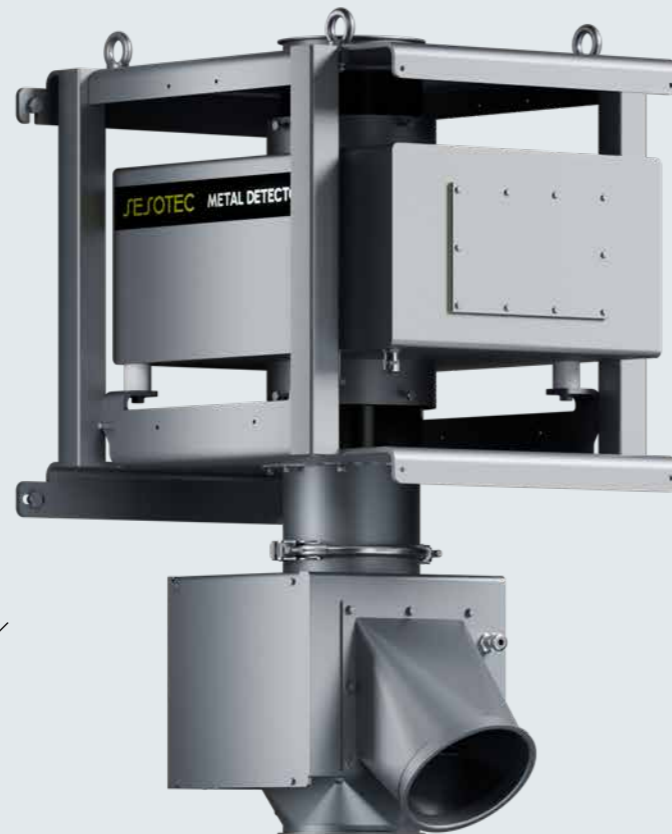

For granular bulk materials in free fall

Free consultation

<https://www.sesotec.com/emea/en/contact>

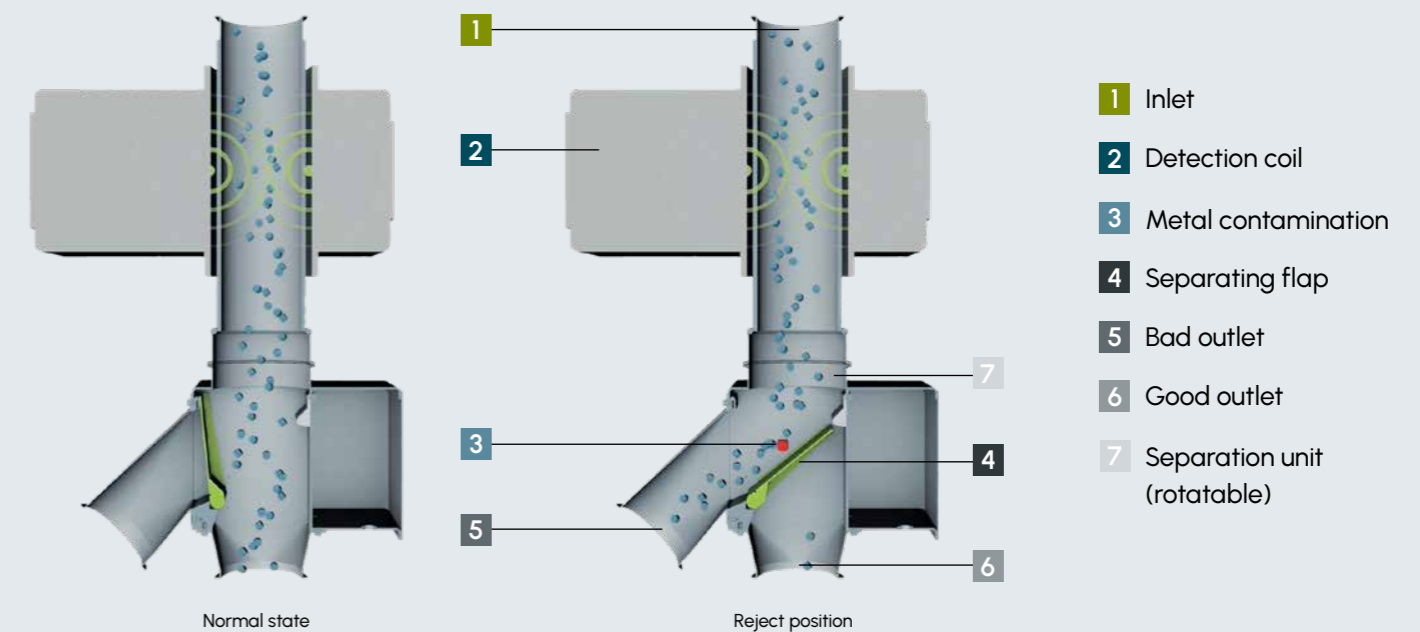

Technical data RAPID 4000

| | |
|---------------------|---|
| Nominal widths | 50–250 mm |
| Detection accuracy | from Ø 0.30 mm FE and 0.50 mm V2A |
| Installation height | 666–1383 mm |
| IP protection class | IP65 |
| Throughput | max. 69,000 l/h |
| Free fall height | 500 mm (optionally up to 1 m) |
| Grain size | Ball Ø=8 mm |
| Grain shape | Grains, granules, regrind, pellets |
| Reject mechanism | Angular mechanism with Quick Flap rejection |
| Product temperature | max +80 °C |
| Delivery pressure | Unpressurized (free fall) |
| Flowability | Medium to good |

Options

| | |
|--|---|
| Automatic function test module | for continuous function testing without additional effort |
| Interfaces IP options | Ethernet, WLAN, USB, Profibus, Profi.NET |
| Available protocols for integration into the company network | OPC-UA, MQTT, Sesotec SSTPROT, Rest API (via COMGateway.Embedded and Insight.360) |

RAPID 5000

For testing fine-grained and powdery bulk materials in free-fall conveying lines with high hygienic requirements

| | | |
|-------------------|-------------------------|-------------------|
| Quick Flap | up to 69,000 l/h | up to 8 mm |
| Mechanics | Throughput | Grain size |

Hygienic design

Hygienic, dead space-free design of the separation unit.

ATEX version

For dust explosion hazardous areas, the RAPID 5000 is also available in a type-tested ATEX version.

Quick Flap

- Reliable rejection of metallic contaminants from 0.3 mm
- Low loss of good material

Easy Clean swivel device

For particularly easy cleaning, the RAPID 5000 has an Easy Clean swiveling device of the Separation unit. After the product flow has been stopped, the separation unit can be swung to the side – for easy access to the separation and detection unit. Thanks to the round separator mechanism, there are also no powder deposits.



For fine-grained and powdery bulk materials in free fall

Free consultation

<https://www.sesotec.com/emea/en/contact>

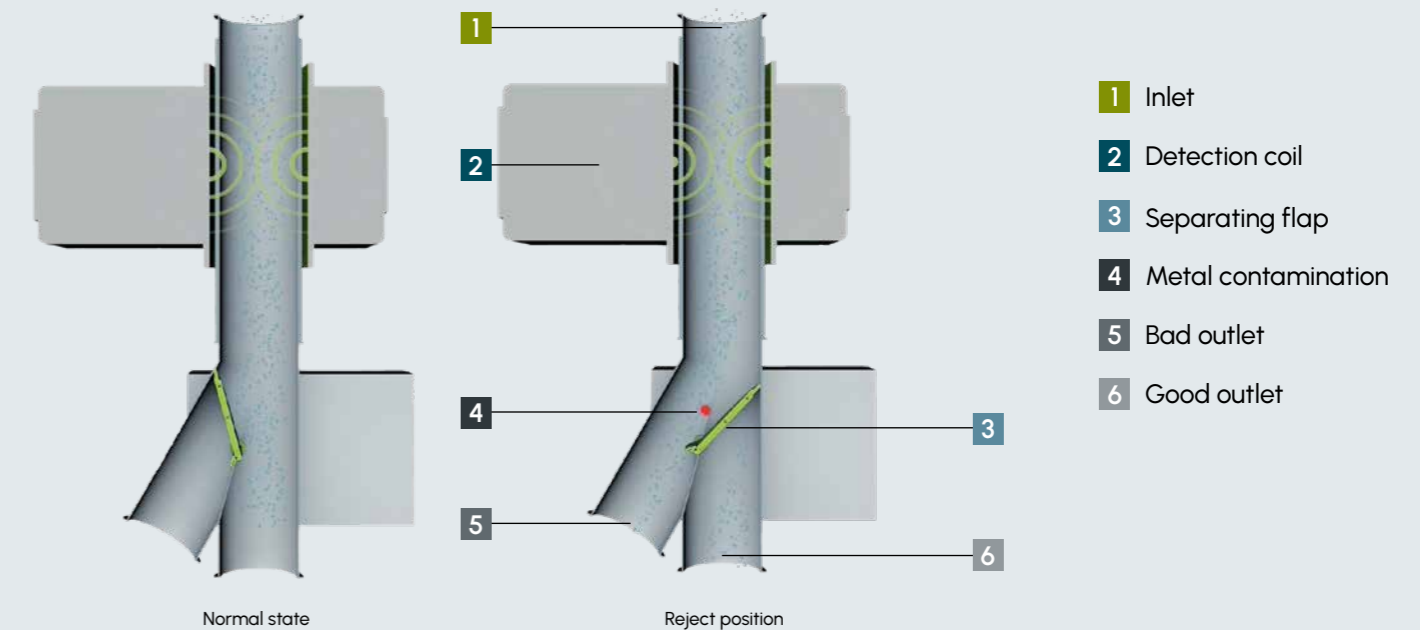

Technical data RAPID 5000

| | |
|---------------------|--|
| Nominal widths | 50–250 mm |
| Detection accuracy | from Ø 0.30 mm FE and 0.50 mm V2A |
| Installation height | 672–1446 mm |
| IP protection class | IP65 |
| Throughput | max. 69,000 l/h |
| Free fall height | 500 mm (optionally up to 1 m) |
| Grain size | Ball Ø=8 mm |
| Grain shape | Powder, fine-grained bulk materials |
| Reject mechanism | Round mechanism (no powder deposits) with Quick Flap rejection |
| Product temperature | max +80 °C |
| Delivery pressure | Unpressurized (free fall) |
| Flowability | Medium to good |

Options

| | |
|--|---|
| Automatic function test module | for continuous function testing without additional effort |
| Interfaces IP options | Ethernet, WLAN, USB, Profibus, Profi.NET |
| Available protocols for integration into the company network | OPC-UA, MQTT, Sesotec SSTPROT, Rest API (via COMGateway.Embedded and Insight.360) |

RAPID 6000

For testing coarse-grained, flaky, fibrous and humid bulk materials in free-fall conveying lines with high hygienic requirements

Swivel
funnel

Mechanics

up to
69,000
l/h

Throughput

up to
20
mm

Grain size

Hygienic design

- Hygienic design of the separation unit with cleaning flap on the reject mechanism
- Cleaning opening with tool-free access for quick and easy cleaning in lines where frequent cleaning cycles are necessary – through a removable hopper and freely accessible separating unit



Auto learn function

Auto-learn function or manual product compensation for optimal adaptation to the intrinsic conductivity of the product under investigation and consequently a lower false rejection rate.

Swivel funnel

Reliable automatic separation of metal impurities by means of a swivel hopper.



For coarse-grained, flaky, fibrous and moist bulk materials in free fall

Free consultation

<https://www.sesotec.com/emea/en/contact>

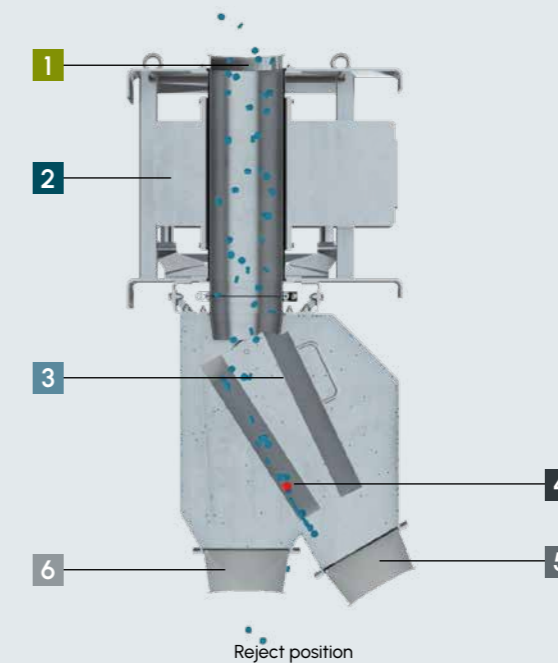
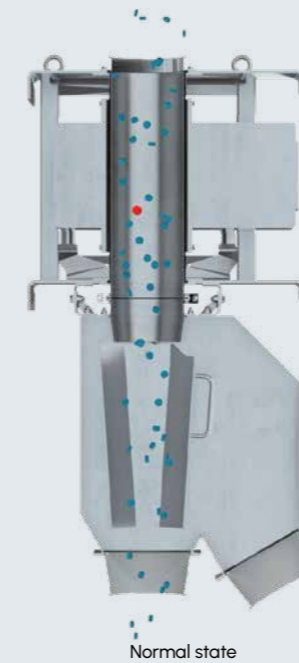

- Inlet
- Detection coil
- Swivel funnel
- Metal contamination
- Bad outlet
- Good outlet

Technical data

RAPID 6000

| | |
|---------------------|---|
| Nominal widths | 50–250 mm |
| Detection accuracy | from Ø 0.30 mm FE and 0.50 mm V2A |
| Installation height | 954-1464 mm |
| IP protection class | IP65 |
| Throughput | max. 69,000 l/h |
| Free fall height | 500 mm (optionally up to 1 m) |
| Grain size | Ø < 20 mm, but also fibrous and lumpy |
| Grain shape | Fine-grained bulk materials, granules, fibers, flakes |
| Reject mechanism | Funnel reject mechanism with cleaning opening |
| Product temperature | max +80 °C |
| Delivery pressure | Unpressurized (free fall) |
| Flowability | Medium to good |

Options

| | |
|--|---|
| Automatic function test module | for continuous function testing without additional effort |
| Interfaces options | Ethernet, WLAN, USB, Profibus, Profi.NET |
| Available protocols for integration into the company network | OPC-UA, MQTT, Sesotec SSTPROT, Rest API (via COMGateway.Embedded and Insight.360) |

RAPID 8000

For testing powdery, fibrous and lumpy bulk materials in free-fall conveying lines with high hygienic requirements

Swivel
funnel

Mechanics

up to
163,000
l/h

Throughput

up to
20
mm

Grain size

Powerful

For highest throughput rates due to the large nominal widths of 300 and 350 mm.

Auto learn function

Auto-learn function or manual product compensation for optimal adaptation to the intrinsic conductivity of the product under investigation and consequently a lower false rejection rate.

Swivel funnel

Reliable automatic separation of metal contaminants by means of a swivel hopper and dust-tight reject outlet.



For fibrous, coarse-grained bulk materials with larger pieces and powdery bulk materials

Free consultation

<https://www.sesotec.com/emea/en/contact>

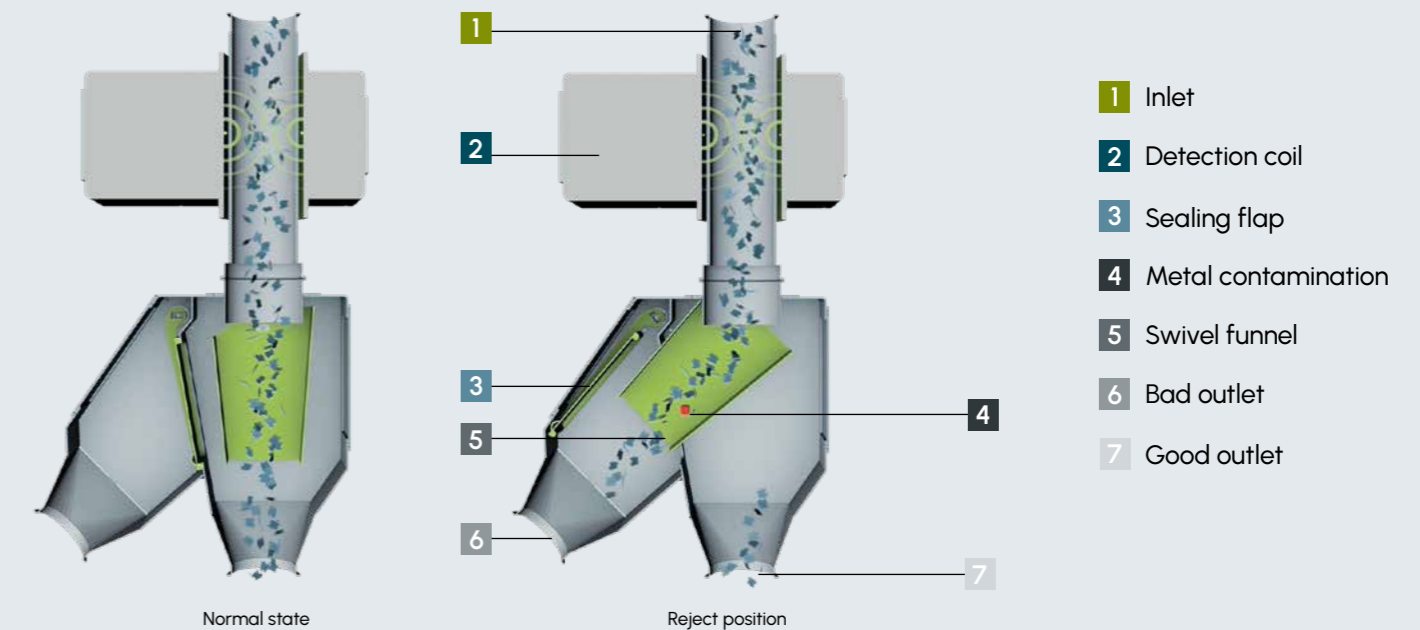

Technical data

RAPID 8000

| | |
|---------------------|---|
| Nominal widths | 50–350 mm |
| Detection accuracy | from Ø 0.30 mm FE and 0.50 mm V2A |
| Installation height | 871–1447 mm |
| IP protection class | IP65 |
| Throughput | max. 136,000 l/h |
| Free fall height | 500 mm (optionally up to 1 m) |
| Grain size | Ø < 20 mm, but also fibrous and lumpy |
| Grain shape | Powder, fine-grained bulk materials, granules, fibers, flakes |
| Reject mechanism | Hopper reject mechanism with dust-tight reject outlet |
| Product temperature | max +80 °C |
| Delivery pressure | Unpressurized (free fall) |
| Flowability | Good, medium, bad |

Options

| | |
|--|---|
| Automatic function test module | for continuous function testing without additional effort |
| Interfaces options | Ethernet, WLAN, USB, Profibus, Profi.NET |
| Available protocols for integration into the company network | OPC-UA, MQTT, Sesotec SSTPROT, Rest API (via COMGateway.Embedded and Insight.360) |

Type-tested ATEX version

The ATEX regulations from EU Directive 2014/34/EU require that within the EU, all equipment used in potentially explosive atmospheres must comply with the recast ATEX Directive. For potentially explosive environments, we offer the RG Detection Unit and the RAPID 5000 in a type-tested ATEX version up to Zone 20 (indoors) and up to Zone 21 (outdoors). Type testing eliminates the need for expensive individual acceptance testing and results in significant cost savings and shorter delivery times. The RAPID 5000 in the ATEX version has a completely dust-tight separating unit.



ATEX version per individual acceptance

Only the RG Detection Unit and the RAPID 5000 are also available in a type-tested ATEX version.

However, the RAPID 4000, the RAPID 6000 and the RAPID 8000 are also available with individual approval in the ATEX version. Just contact us.

GENIUS ONE Control Unit – Structural adaptations and measures for ATEX conformity

Adapted Control Unit GENIUS ONE EX

- with tested dustproof housing
- ATEX certified cable entry
- Permanently connected housing (no plugs in EX zones)
- Ground connection outside
- Remote control unit in ergonomic position with up to 10m cable length



Advantages for the customer

- short delivery times due to type testing
- Cost savings
- Problem-free use of ATEX-certified devices in potentially explosive atmospheres
- Safe operation in hazardous areas

RAPID 5000 – Structural adaptations and measures for ATEX conformity

- ATEX certified electronics housings
- Separation mechanism with dust-tight flap especially for conveying powders and fine-grained bulk materials
- Grounding concept (all metal parts grounded to prevent static charges)
- Conductive sensing tube (also included in standard)
- ATEX-compliant output tests and measurements (discharge capability, grounding, temperature measurements) and storage of documents

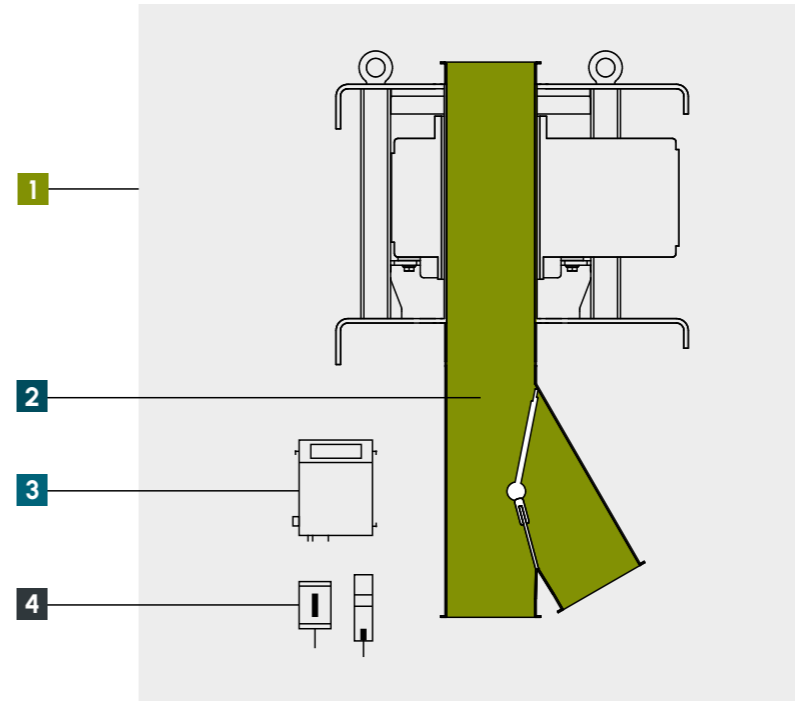

Dust Ex Zones

- Zone 20**
Explosive atmosphere constantly present
- Zone 21**
Explosive atmosphere frequently present
- Zone 22**
Explosive atmosphere rarely present

| Area | Possible dust Ex zones |
|--|------------------------|
| 1 Outside of the metal separator | None, 21, 22 |
| 2 Inside the pipeline | 20, 21, 22 |
| 3 At the Control Unit | None, 21, 22 |
| 4 On options (e.g. signal lamp, function button) | None, 21, 22 |

Tubular magnet for free-fall applications

Our tubular magnets have been specially developed for free-fall applications and can be quickly and easily integrated into all production lines for bulk materials. Thanks to their extremely high magnetic performance, they reliably separate the finest magnetic metal contaminants from the bulk material falling through them.

Advantages of MAGBOX FOOD and CHUTE MAGNET

By combining metal separators and magnetic separators, you benefit from:

- Significantly less loss of good material
- A lower stress on the excretory mechanics
- Thorough separation of fine and ultra-fine ferrous metal contaminants and even slightly magnetized stainless steel particles thanks to the high magnetic performance of up to 1,370 mT (13,700 Gauß)
- Applicable in ATEX up to zone 20



MAGBOX FOOD









CHUTE MAGNET

Magnet with Easy Clean

- The magnetic cores can be separated from the stainless steel housing by hand
- The impurities then fall off without any problems
- This Easy Clean function results in user-friendly, clean separation

Typical fields of application

The application matrix below shows the possible uses of the individual systems – metal separators and pipe magnet – for various free-fall applications.

| | Metal separators | | | | Magnets | |
|--|------------------|------------|----------------|----------------|----------------|----------------|
| | RAPID 4000 | RAPID 5000 | RAPID 6000 | RAPID 8000 | MAGBOX FOOD | CHUTE MAGNET |
|  Powder poor flowability, may deposit in the separating unit, e.g. flour, powdered sugar, fine spices | × | ✓ | × | ✓ | ✓ ¹ | ✓ ¹ |
|  Sticky powder poorly free-flowing, e.g. cocoa powder | × | ✓ | × | × | × | ✓ ¹ |
|  Crystalline bulk solids good free-flowing, e.g. salt, sugar | × | × | ✓ ³ | ✓ ³ | ✓ ⁴ | ✓ ⁴ |
|  Ground bulk materials free-flowing, e.g. coarsely ground herbs, oat flakes, semolina | ✓ | ✓ | × | ✓ | ✓ | ✓ |
|  Grains free-flowing well, e.g. rice, corn, coffee beans | ✓ | ✓ | ✓ | ✓ | ✓ | ✓ |
|  Flakes poorly free-flowing, tends to form „bridges“, e.g. chips, popcorn, cornflakes | × | × | ✓ | ✓ | ✓ ⁵ | ✓ |
|  Fibers and leaves medium to poor flowability, e.g. tea | × | × | ✓ | ✓ | × | ✓ |
|  Larger pieces medium free-flowing due to the size of the piece, e.g. nuts, pasta, dried fruits | × | × | ✓ | ✓ | × | ✓ |

1 design changes may be necessary (not possible in the standard version)
 2 Wear of the damper seal is to be expected
 3 with wear-protected sensing tube
 4 with wear protection coating
 5 depending on the concrete size of the pieces (not possible in the standard version)
 6 depending on the size of the pieces, design changes may be necessary (not possible in the standard version)



Imprint

SESOTEC

Sesotec GmbH
Regener Strasse 130
D-94513 Schönberg

Phone: +49 (0) 8554 / 308-0
Mail: info@sesotec.com
Website: www.sesotec.com

Managing Director: Joachim Schulz

Register court: Local court Passau
Commercial register no. HRB 3163

Sales tax identification number:
DE 81 151 25 77

Concept, text, design:
Sesotec GmbH

Picture credits/Copyright:
All image rights reserved by
the company Sesotec GmbH.